

AVerMedia[®] **AVerDiGi** **EXR6004 WiFi**

User Manual



FCC NOTICE (Class B)



This device complies with Part 15 of the FCC Rules. Operation is subject to the following two conditions: (1) this device may not cause harmful interference, and (2) this device must accept any interference received, including interference that may cause undesired operation.

Federal Communications Commission Statement

This equipment has been tested and found to comply with the limits for a Class B digital device, pursuant to Part 15 of the FCC Rules. These limits are designed to provide reasonable protection against harmful interference in a residential installation. This equipment generates uses and can radiate radio frequency energy and, if not installed and used in accordance with the instructions, may cause harmful interference to radio communications. However, there is no guarantee that interference will not occur in a particular installation. If this equipment does cause harmful interference to radio or television reception, which can be determined by tuning the equipment off and on, the user is encouraged to try to correct the interference by one or more of the following measures:

- Reorient or relocate the receiving antenna.
- Increase the separation between the equipment and receiver.
- Connect the equipment into an outlet on a circuit different from that to which the receiver is connected.
- Consult the dealer or an experienced radio/television technician for help.

IMPORTANT NOTE

FCC Radiation Exposure Statement

This equipment complies with FCC radiation exposure limits set forth for an uncontrolled environment. End user must follow the specific operating instructions for satisfying RF exposure compliance.

This transmitter must not be co-located or operating in conjunction with any another antenna or transmitter.

FCC Caution: Any changes or modifications not expressly approved by the party for responsible for compliance could void the user's authority to operate this equipment.

European Community Compliance Statement (Class B)



This product is herewith confirmed to comply with the requirements set out in the Council Directives on the Approximation of the laws of the Member States relating to Electromagnetic Compatibility Directive 2004/108/EC.

DISCLAIMER

No warranty or representation, either expressed or implied, is made with respect to the contents of this documentation, its quality, performance, merchantability, or fitness for a particular purpose. Information presented in this documentation has been carefully checked for reliability; however, no responsibility is assumed for inaccuracies. The information contained in this documentation is subject to change without notice.

In no event will AVerMedia be liable for direct, indirect, special, incidental, or consequential damages arising out of the use or inability to use this product or documentation, even if advised of the possibility of such damages.

TRADEMARKS

"AVerMedia" is a trademark (or registered trademark) of AVerMedia Technologies, Inc and has been authorized AVerMedia Information Inc to use. Other trademarks used herein for description purpose only belong to each of their companies.

COPYRIGHT

©2009-2010 by AVerMedia Information, Inc. All right reserved.

No part of this document may be reproduced or transmitted in any form, or by any means without the prior written permission of AVerMedia Information Inc. AVerMedia Information Inc. reserves the right to modify its models, including their characteristics, specifications, accessories and any other information stated herein without notice. The official printout of any information shall prevail should there be any discrepancy between the information contained herein and the information contained in that printout.



The mark of Crossed-out wheeled bin indicates that this product must not be disposed of with your other household waste. Instead, you need to dispose of the waste equipment by handing it over to a designated collection point for the recycling of waste electrical and electronic equipment. For more information about where to drop off your waste equipment for recycling, please contact your household waste disposal service or the shop where you purchased the product.

Battery Safety Information

- Store the batteries in a cool dry place.
- Do not dispose of used batteries in domestic waste. Dispose of batteries at special collection points or return to point of sale if applies.
- Remove the batteries during long periods of non-use. Always remove exhausted batteries from the remote control. Battery leakage and corrosion can damage this remote control, dispose of batteries safely.
- Do not mix old and new batteries.
- Do not mix different types of batteries: alkaline, standard (carbon-zinc) or rechargeable (nickel-cadmium).
- Do not dispose of batteries in a fire. The batteries may explode or leak.
- Never short circuit the battery terminals.

**WARNING**

TO REDUCE RISK OF FIRE OR ELECTRIC SHOCK, DO NOT EXPOSE THIS APPLIANCE TO RAIN OR MOISTURE

**CAUTION**

IF THERE IS ANY DAMAGE, SHORTAGE OR INAPPROPRIATE ITEM IN THE PACKAGE, PLEASE CONTACT WITH YOUR LOCAL DEALER. WARRANTY VOID FOR ANY UNAUTHORIZED PRODUCT MODIFICATION

**NOTICE**

- INFORMATION IN THIS DOCUMENT IS SUBJECT TO CHANGE WITHOUT NOTICE.
- THE INFORMATION CONTAINED HEREIN IS TO BE CONSIDERED FOR REFERENCT ONLY.

Table of Contents

Chapter 1 Introduction	1
1.1 Package Content	2
1.2 Front Panel	3
1.3 Back Panel	4
1.4 Setting Up the DVR Unit	5
1.4.1 Installing the Hard Disk	5
1.4.2 Connecting Devices	7
1.4.3 Connecting the Audio, Sensor and Relay device	8
Chapter 2 Operating the DVR unit	9
2.1 The Way to Operate DVR	9
2.2 First Time Using the DVR Unit	9
2.2.1 To Connect the Wireless IP Camera	10
2.2.1.1 Connecting IP Camera in Wireless mode	10
2.2.1.2 Connecting IP Camera Through the Ethernet Cable	11
2.2.2 To Format the Hard Disk	12
2.3 Familiarizing the Buttons in Preview Mode	13
2.3.1 Setting Up and Using the Emap	15
2.3.1.1 To Set Up the Emap	15
2.3.1.2 To Use the Emap	15
2.3.2 Using Event Log Viewer	16
2.4 To Playback the Recorded Video	17
2.4.1 To Cut and Save the Wanted Portion of the Recorded Video	19
2.4.2 To Bookmark a Video Section	19
2.4.3 Using the Event Search	20
Chapter 3 Customizing the DVR System	21
3.1 Basic Setup Mode	21
3.2 System Setup	23
3.3 Camera Setup	27
3.3.1 To Setup the Wireless IP Camera	27
3.3.2 To Setup Camera from the Remote DVR	29
3.4 Recording Setup	30
3.5 Network Setup	31
3.6 Schedule Setting	34
3.7 Backup Setup	35
3.7.1 Using QPlayer to Playback Backup Video	36
3.7.2 To Cut and Save the Portion of the Recorded Video	38
3.7.3 To Search Using the Visual Search	38
3.7.4 To Search Using the Event Search	39
3.7.5 To Search Using the Intelligent Search	39

3.8	Sensor Setting	40
3.9	Relay Setting	41
3.10	Alarm Setting	42
3.11	User Setup	46
Chapter 4 Using the USB Playback Console		48
4.1	Recommended system requirements	48
4.2	Installing the USB Playback Console	48
4.3	Running the USB Playback Console	49
4.3.1	To Cut and Save the Portion of the Recorded Video	51
4.3.2	Playback DVR Recorded File from Hard Disk	51
4.3.3	Playback Backup File(*.dvr)	52
4.3.4	To Backup Recorded File	53
Chapter 5 iEnhance		54
5.1	To Use iStable	55
Chapter 6 Using the Remote Programs		56
6.1	Familiarizing the Buttons in WebViewer	57
6.1.1	To Setup Remote System Setting	59
6.1.1.1	System Setting	59
6.1.1.2	Camera Setting	60
6.1.1.3	Record Setting	63
6.1.1.4	Network Setting	65
6.1.1.5	Alarm Setting	67
6.2	Familiarizing the Buttons in Remote Console	71
6.2.1	To Setup Remote Console Setting	72
6.3	Using the Remote Playback	73
6.3.1	Familiarizing the Buttons in Local Playback	74
6.3.1.1	To Cut and Save the Wanted Portion of the Recorded Video	76
6.3.1.2	To Search Using the Visual Search	76
6.3.2	Familiarizing the Buttons in RealTime Playback	77
6.3.3	Familiarizing the Buttons in Download and Playback	79
Chapter 7 Using HandyViewer to Access DVR Server		80
7.1	Using PDAViewer to Access DVR Server	80
7.1.1	To install PDAViewer thru ActiveSync	80
7.1.2	To install PDAViewer from the Internet	81
7.1.3	To Use the PDAViewer	82
7.1.4	To Playback in PDAViewer	83
7.2	Using JavaViewer to Access DVR Server	85
7.2.1	To install JavaViewer from the DVR Server	85
7.2.2	To Use the JavaViewer	85
Chapter 8 Web Tools		87
8.1	Dispatch Server	87
8.1.1	To Run Dispatch program:	87

8.2	Remote Setup.....	88
8.2.1	To Add DVR server.....	88
8.2.2	To Setup Remote System Setting	89
8.2.2.1	System Setting	89
8.2.2.2	Camera Setting.....	90
8.2.2.3	Record Setting.....	93
8.2.2.4	Network Setting	95
8.2.2.5	Alarm Setting.....	97
8.3	Remote Backup	101
8.3.1	To back up the recoded data from the DVR server:	101
Appendix A	Registering Domain Name.....	104

Chapter 1 Introduction

AVerDiGi EXR6004 WiFi is the instant video surveillance system that can be fully installed by anyone in less than 3 minutes. Simply open the box, power on the included wireless megapixel IP camera, plug the unit in and instantly the monitored area is under the watchful eye of a powerful video surveillance system - no appointments, costly cabling or power tools necessary! It's your best home surveillance choose.

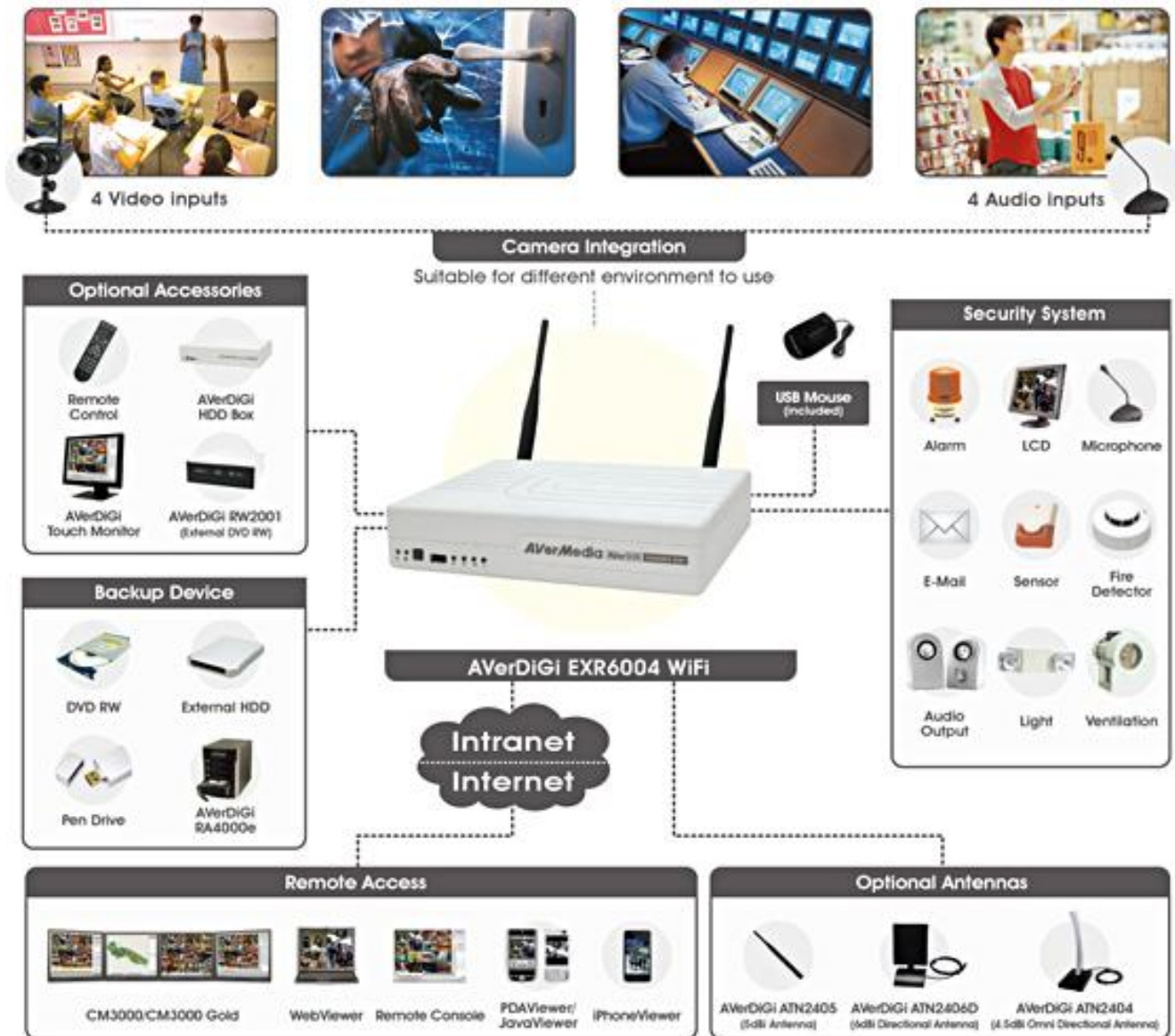

Application Diagram

1.1 Package Content

The package content has two parts – DVR unit and Wireless IP camera.

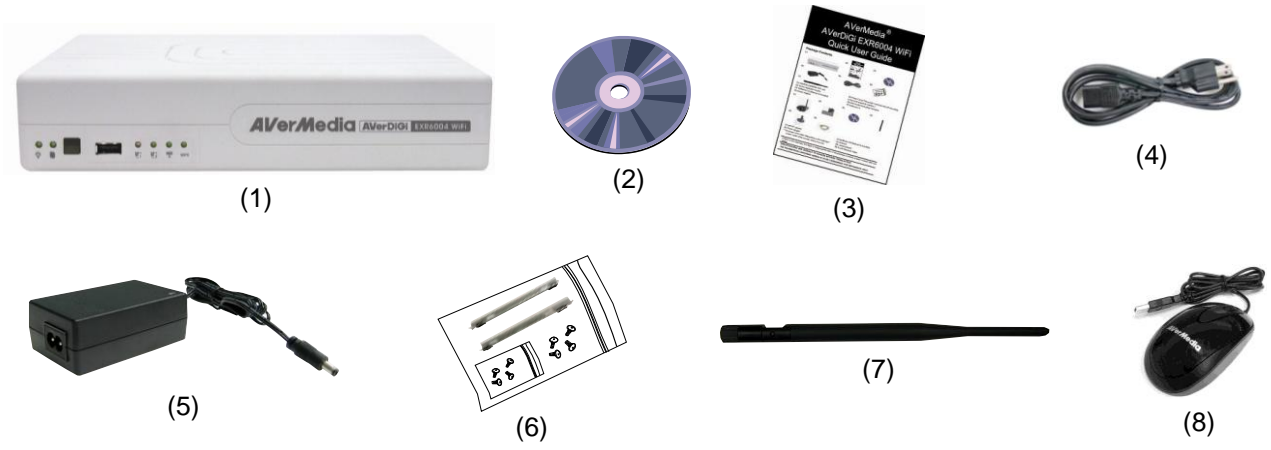

- (1) AVerDiGi EXR6004 WiFi unit
- (2) Software CD (User Manual included)
- (3) Quick User Guide
- (4) Power Cord
 - * The power cord varies depending on the standard power outlet of the country where it is sold.
- (5) Power Adapter
- (6) Internal HDD holder (8 screws are included)
- (7) 2 * Antenna
- (8) AVerMedia USB optical mouse

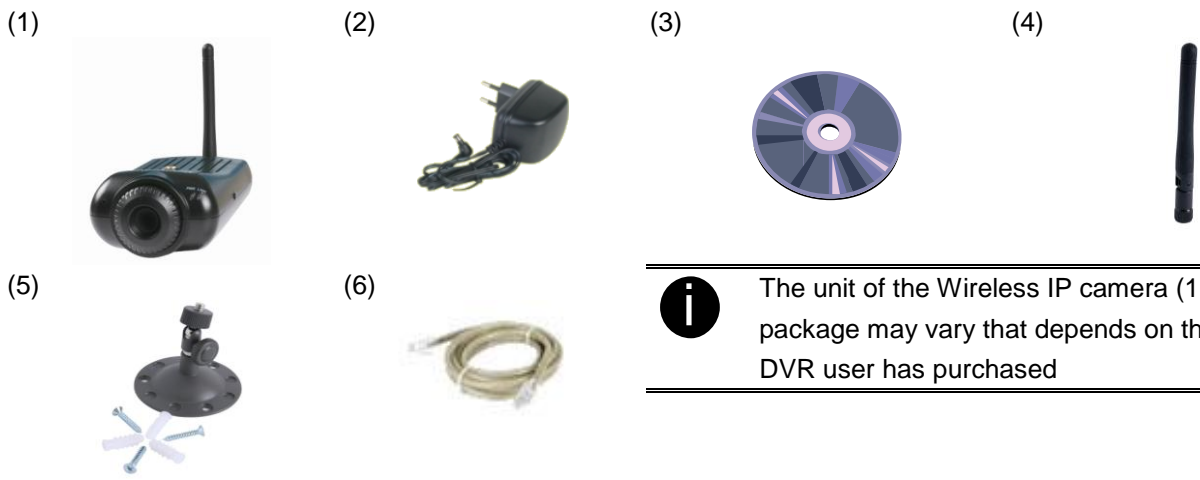



i The unit of the Wireless IP camera (1 or 4) in package may vary that depends on the model of DVR user has purchased

- (1) Wireless IP Camera unit
- (2) Power Cord
 - * The power cord varies depending on the standard power outlet of the country where it is sold.
- (3) Software CD (User Manual included)
- (4) Antenna
- (5) Camera Stand(screws included)
- (6) RJ-45 Ethernet Cable

i If there is any damage, shortage or inappropriate item in the package contents, please contact with local dealer

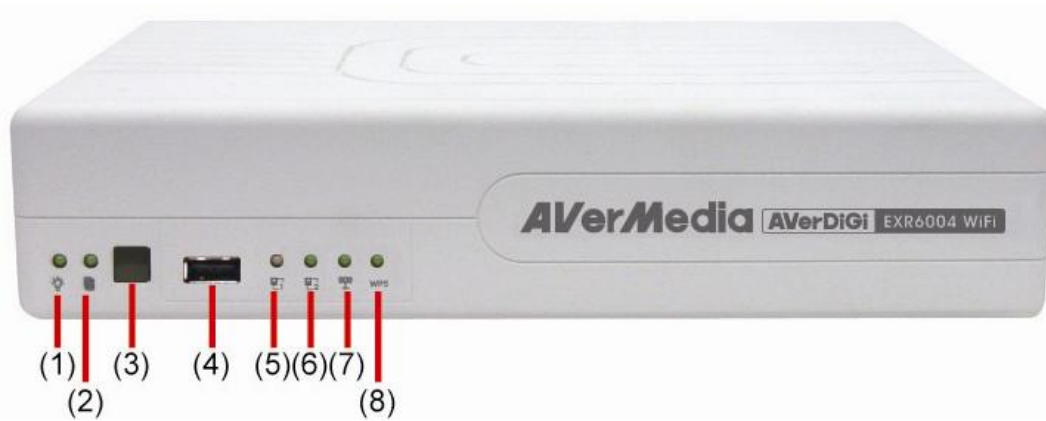
1.2 Front Panel



Name	Function
(1) DVR Power LED 	Light when the unit is power on
(2) HDD LED 	Indicate the hard disk running state. Light when the HDD is running (Read/Write)
(3) IR Sensor	Receive signal from the remote control to operate the unit
(4) USB 2.0 Port	For pen drive/DVD-ROM connection
(5) Network 1 Indicator	Indicate the status of network 1
(6) Network 2 Indicator	Indicate the status of network 2
(7) Wireless Indicator	The indicator will light up when the WPS is enabling.
(8) Wireless Status Indicator	To indicator the wireless status. When the wireless is working normally, the indicator will light up and flash in green light.

1.3 Back Panel

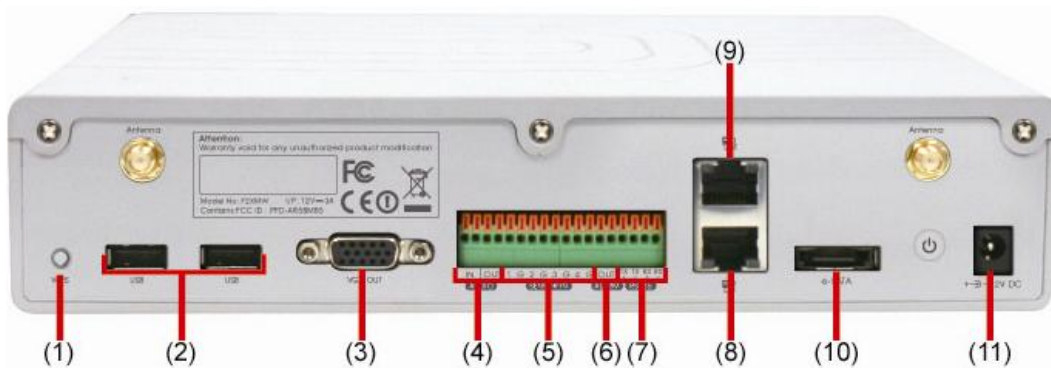

Name	Function
(1) WPS button	Pressing to enable the WPS function.
(2) 2* USB 2.0 ports	For USB keyboard, mouse, and other USB devices connection.
(3) VGA Out	Output the video signal to a CRT or LCD monitor
(4) Audio In/Out	<ul style="list-style-type: none"> - Audio In: Input the audio signal from audio input device such as microphone - Audio Out: Output the audio signal to a audio out device such as speaker
<div style="display: flex; align-items: center; justify-content: center;"> <div style="border: 1px solid black; border-radius: 50%; width: 20px; height: 20px; display: flex; align-items: center; justify-content: center; margin-right: 5px;"> i </div> <div> <p>The audio input/output device has its own power supply is necessary.</p> </div> </div>	
(5) Sensor In	Support 4 sensor devices
(6) Alarm Out	Support 1 relay device (Relay: 1A @ 125V AC/30V DC)
(7) RS-485	For future function, no support now.
(8) Gigabit LAN port	LAN connection but default assign as a DHCP service port. User also can connect the IP camera through the Ethernet cable.
(9) Gigabit WAN port	For connect with switch or router on your network for internet connection.
(10)e-SATA port	For connecting external RAID
(11)12V DC	Power cable connection

1.4 Setting Up the DVR Unit

1.4.1 Installing the Hard Disk



- For hard disk spec, please referring to <http://www.avermedia.com/AVerDiGi/Product/> → **AVerDiGi EXR6004 WiFi** → **Hardware Recommendations**
- The DVR unit may include hard disk that depends on the model user has purchased. If the model user has purchased is included hard disk, user doesn't need to install the hard disk by yourself.
- The external USB hard disk only supports on file backup. Please **do not** install the external USB hard disk for recording purpose.



The “compatible hard disks” indicated in the above recommendation list only means that these commercially available hard disks were tested with AVerMedia products and functioned well under normal operation conditions. AVerMedia does not guarantee or provide warranties, explicitly, implied or statutory with respect to the reliability of the hard disk function or its compatibility. In no event AVerMedia shall be liable for damages, with respect to any business interruption of clients, lost profits, loss of programs or other data on your information handling system or otherwise. This includes direct, indirect, incidental, special, or consequential damages, resulting from the incompatibility caused by the usage of these hard disks, even if AVerMedia has expressly advised about the risk of such damages. The entire risk arising out of the use of any information attached here with is borne by the recipient.

The DVR unit allows user to install one hard disk. Follow the illustrated instructions below to install the hard disk:

1. Loosen all screws



2. Push the cover backward and lift



3. Secure the HDD holder on the hard disk. The position to screw the HDD holder on hard disk must same as figure shown. Otherwise, the hard disk won't be able to fit into inside the DVR unit.



4. Connect the the SATA cable and the power connector to the hard disk



5. Secure the hard disk inside the unit then place unit cover
6. Push the cover forward and secure the cover



7. You may now connect all the cables. When the power is connected, the Power LED light  turns on

1.4.2 Connecting Devices

The back panel of the DVR unit, user can connect the 4 sensor devices, 1 alarm device, audio input/output device and an external HDD storage device. Through the Gigabit LAN ports can connect with the IP cameras and allows user to remote access the DVR server. The USB ports can connect the mouse and keyboard for more easily to operate DVR server.

Follow the illustration below to make the connection:

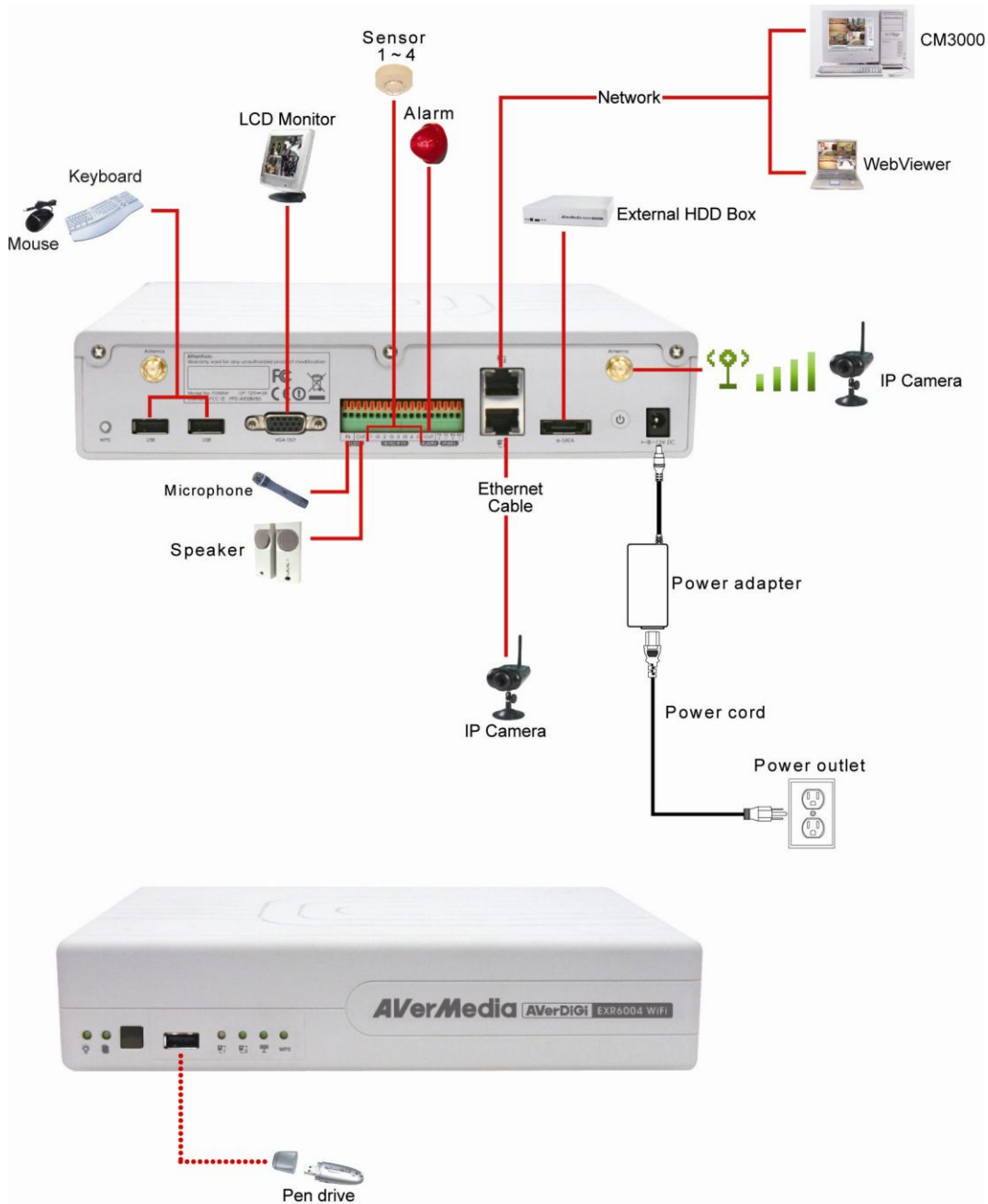

- The port LAN1 that is located at lower position of the back panel is a DHCP service port in default.
- To connect more than one IP camera through the Ethernet cable, please connect the switch (DHCP function disabled) or hub (DHCP function disabled) to the DVR unit, and then, connect the IP cameras to the switch or hub.



- Port LAN1 that locate at lower position of the back panel only support SF1301(W) IP camera through Ethernet cable. The DVR system will detect and configure the camera automatically when the connection is made through the Ethernet cable.
- Port LAN2 is configurable for PPPOE, DHCP, or Fixed IP of the network mode.

1.4.3 Connecting the Audio, Sensor and Relay device

The Sensor, Alarm, and audio port enable you to connect 4 sensor inputs, 1 relay outputs, and 1 audio in and 1 audio out device. Just connect the external sensor, relay, and audio in/out device pin directly to the pinhole. The RS-485 port can be used for POS system connection through an AVerDiGi Data Box.

Check the table below and locate which pinhole is assigned to sensor input, relay output, and audio in/out.

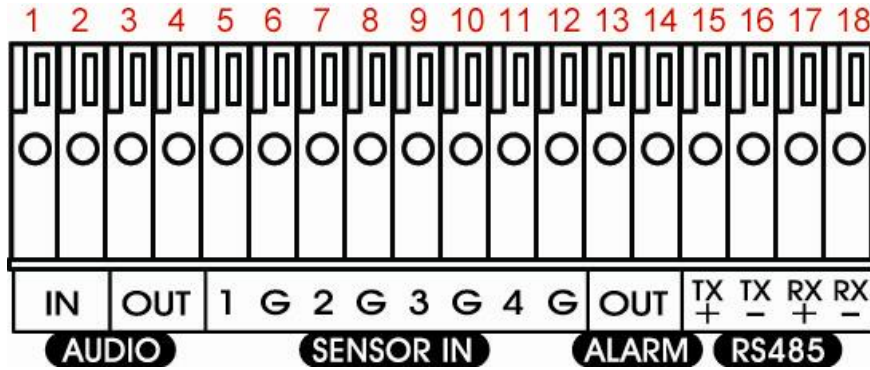

The signal from the sensor (i.e., infrared sensors, smoke detectors, proximity sensors, door sensors, etc.) is being transmitted to the unit and this triggers the system to respond and send signal to relay device (i.e., alarm, telephone etc).

Audio in and out pinhole:

Pin #	Definition
1	Audio input signal
2	Audio Ground signal
3	Audio output signal
4	Audio Ground signal

Sensor and Alarm pinhole:

Pin #	Definition
5	Sensor 1 signal
6	Sensor 1 Ground signal
7	Sensor 2 signal
8	Sensor 2 Ground signal
9	Sensor 3 signal
10	Sensor 3 Ground signal
11	Sensor 4 signal
12	Sensor 4 Ground signal
13	Relay signal
14	Relay signal

RS-485 pinhole:

Pin #	Definition
15	RS485 TX+ signal
16	RS485 TX- signal
17	RS485 RX+ signal
18	RS485 RX- signal

Chapter 2 Operating the DVR unit

2.1 The Way to Operate DVR

■ Using mouse and keyboard

Connecting the mouse and keyboard through USB interface, user can manage the DVR unit easily. For the first time using DVR unit, mouse and keyboard is the best way to set up all DVR relevant configurations.

2.2 First Time Using the DVR Unit

For the first time using the DVR server, user needs to setup the connection between DVR server and Wireless IP cameras.

Please confirm the following items before connecting with the DVR server and IP cameras.

- Make sure the HDD is installed inside the DVR unit.
- Make sure the antennas are installed on the DVR unit.
- Make sure all the connecting devices are well connected with the DVR unit and have their own power supply.
- Make sure the DVR unit is connected on your network and power on.
- Make sure the IP cameras are power on.
- Please make sure the DVR unit and IP camera are in communication area.



- For get better wireless communication and stability, do not use the DVR unit around following devices.
 - Microwave ovens.
 - Wireless transmitters (radio transmitters, cellular transmitters, etc.)
 - Wireless devices which operate at 2.4 GHz (security equipment, Bluetooth, Zigbee, cordless telephones, etc.)
 - Wireless communication range and quality may be affected if the following types of objects are located between or near the DVR unit and other wireless devices connected to the DVR unit.
 - Metal door shutters
 - Walls made of concrete, stone, or brick, or walls which contain aluminum based heat insulation
 - Multiple walls
 - Fire doors and glass
 - Steel racks or shelves
 - Place cameras and the DVR unit at least **2 m (6.5 ft.)** away from radios. **Do not** connect cameras and the DVR unit to a power outlet used by a radio.
 - Maximum wireless communication range is **30 m** in case that there are no obstacles between camera(s) and AVerDiGi EXR6004 WiFi
 - The DVR system starts up will take a while, please be patient and wait.
-

2.2.1 To Connect the Wireless IP Camera

There are two to connect with the IP camera, one is through the **WiFi signal** and another one is using **Ethernet cable**. Refer the following install description to connect the IP camera to the DVR unit.



EXR6004 WiFi only support SF1301W IP camera.

2.2.1.1 Connecting IP Camera in Wireless mode

1. Please make sure the DVR unit and IP camera are in communication area.
2. Press and hold the **WPS** button of the DVR unit. To release button until hear the beep sound. The **Wireless indicator** that is located at front panel of the DVR unit will light up.



WPS button



WPS Indicator

3. Press and hold the **WPS** button of IP camera until the **power LED** turns off (about 5 seconds), and then, the LED will start to blink at every 2 seconds. And then, wait about 120 seconds for IP camera to communicate with the DVR unit.



WPS button

Power LED

4. If the DVR unit and IP camera has successful to communicate. The Wireless status indicator that is located at front panel of the DVR unit will start flashing.



Wireless Status Indicator

5. And, the surveillance monitor should see the live video from IP camera.



Preview UI

2.2.1.2 Connecting IP Camera Through the Ethernet Cable

In such following condition, user can connect the IP camera by using Ethernet cable.

- IP camera doesn't support wireless function.
- IP camera and DVR unit is out of wireless communication range.
- Location or environment of the IP camera or DVR unit has too many interference for the wireless signal transmitting.

1. Remove the antenna of the IP camera in case the wireless signals may affect the connection if the IP camera has an antenna.

i Set the IP camera to **DHCP** mode or **RESET** the IP camera back to the factory default value, in order to make connection with DVR unit correctly. To reset the IP camera, press reset button which located at the back of the IP camera for 3 seconds.

2. Plug the RJ-45 Ethernet cable into the LAN port of the IP camera.

i To connect more than one IP camera through the Ethernet cable, please connect the switch (DHCP function disabled) or hub (DHCP function disabled) to the DVR unit, and then, connect the IP cameras to switch or hub.



3. And then, plug another side of the Ethernet cable into the LAN1 port of the DVR unit.



4. Wait for the DVR system to detect the IP camera. When DVR system receives the live video from the IP camera, it means the connection is successful.
5. The channel is connecting through the Ethernet cable; there is no wireless signal icon display on the preview screen.



Preview Mode UI

2.2.2 To Format the Hard Disk

The hard disk must be formatted before can be used to record the video.

1. Click **Setup** and enter the ID and password(Default ID is **superuser** and password is **111111**).
2. Click **System**. Click **Switch to Advance Setup** if the setup mode is in **Basic Setup** mode.



3. Click **Add** to call out **Disk Management** window. Select the hard disk and click **Format**.
4. And then, click **Start** to format the selected hard disk.

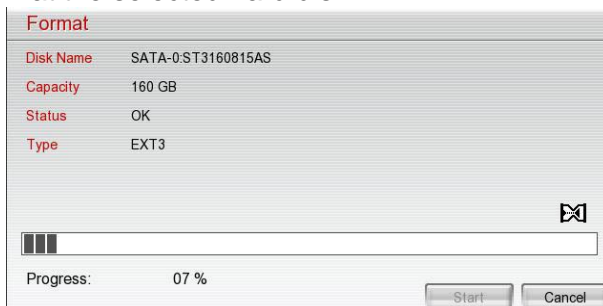

5. When the formatting is done, click **Cancel** to exit.
6. Now, user can click **Record** button to start recording.



Preview UI

2.3 Familiarizing the Buttons in Preview Mode

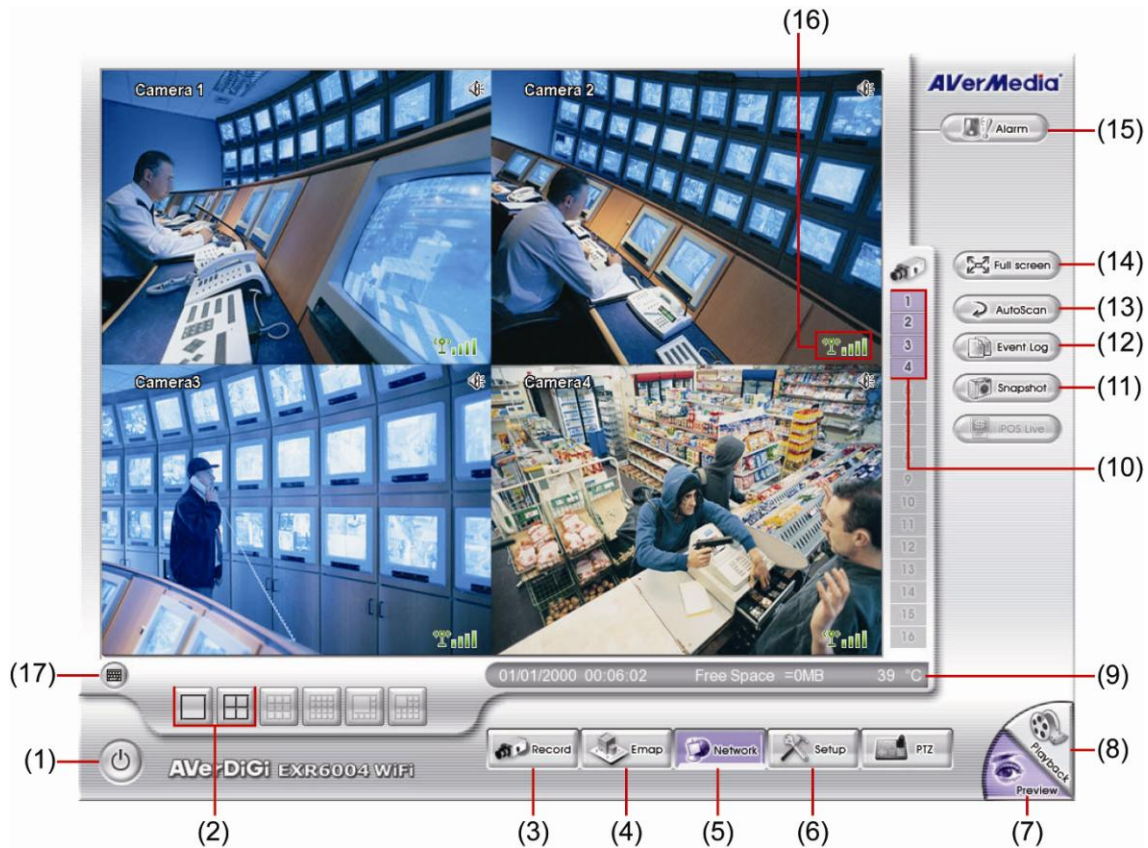

Name	Function
(1) Exit	Call up the Logout dialog box. In the logout dialog box, you may do the following: Reboot: To restart the DVR system. It is required to enter the password Power Off: To shutdown the DVR system. Login: Using different ID to login to DVR system. Exit: To close the application.
(2) Split Screen Mode	Select from 2 different split screen types to view all the cameras or one camera on a single screen. It also allows you to switch and view different camera number. When user is in single screen mode, user can right-click and drag a square on the area you want to enlarge the view. Right-click on the screen again will return to the normal view.
(3) Record	Start/stop video recording.
(4) EMap	Display the map in each area, and the location of camera/ sensor/ relay and the warning (see also Chapter 2.3.1).
(5) Network	Enable/disable remote system access. This feature allows you to access DVR server from a remote location via internet connection. The default is disabled.
(6) Setup	Configure the system settings. (see also Chapter 3)
(7) Preview	Switch to Preview mode. This allows you to view live camera display.
(8) Playback	Switch to Playback mode. This allows you to view the recorded video file. (see also Chapter 2.4)
(9) Status bar	Display the recording date, time and hard disk space of DVR unit.
(10) Camera ID	Show the number of cameras that are being viewed. When you are in single screen mode, click the camera ID number to switch and view other camera.
(11) Snapshot	Capture and save the screen shot in *.jpg format.
(12) Event log	Show the record of activities that take place in the system. (see also Chapter 2.3.2)
(13) AutoScan	Start/Stop video screen cycle switch.

Name	Function
(14) Full screen	<p data-bbox="435 159 1465 226">View in full screen. To return, press the right button of the mouse or ESC on the keyboard or click the arrow icon.</p>  <p data-bbox="435 813 1465 875">When you switch to full screen in multiple-screen mode, Left click to toggle to only display one of the video in the multiple-screen mode or all.</p>
(15) Alarm	Alert and display warning info.
(16) WiFi Signal	Display the strength of the WiFi signal
(17) Virtual Keyboard	If the keyboard is not available, you may use the Virtual Keyboard.

2.3.1 Setting Up and Using the Emap

E-Map can hold up to 8 maps in *.jpg format. You may locate the camera, sensor and relay on the map.

2.3.1.1 To Set Up the Emap

1. Click **Emap**.
2. When the Emap screen appears, click the area number (1 to 8 buttons) on where you want to insert the map.
3. Click **Load Map** to insert the map. When the open dialog box appears, locate and select the map and click **Open**.
4. When the inserted map appears on the Emap screen, click **Edit**. You may now drag the camera, sensor, and relay icons to its place on the map. Icons on the map can be relocated anywhere. If you are going to locate the icon on the map to other area, you need to drag the icon to the black pane at the bottom of the Emap screen and then switch to the area on where you want to locate the icon. To bring all the icons back to the black pane at the bottom of the Emap screen, click **Reset Icon**.
5. When you are done, click **Save** button to save the new setting. To exit Emap screen, click **Close**.

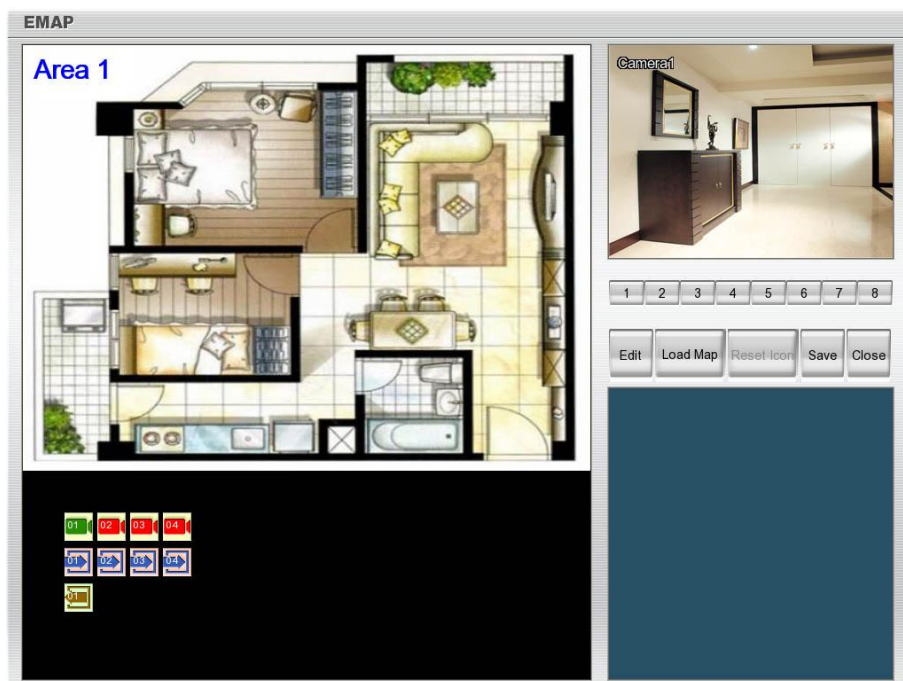

2.3.1.2 To Use the Emap

1. Click **E-map**.
2. In the Emap screen, click the camera icon to switch on the area where the camera is located on the map and to display the video at the upper right corner of the Emap screen. At the lower right corner of the Emap screen, it lists all the warning message.
3. To view different Emap, click Emap number button (1 ~ 8).
4. Click **Close** to exit Emap screen.

2.3.2 Using Event Log Viewer

Show the record of activities that take place in the system.

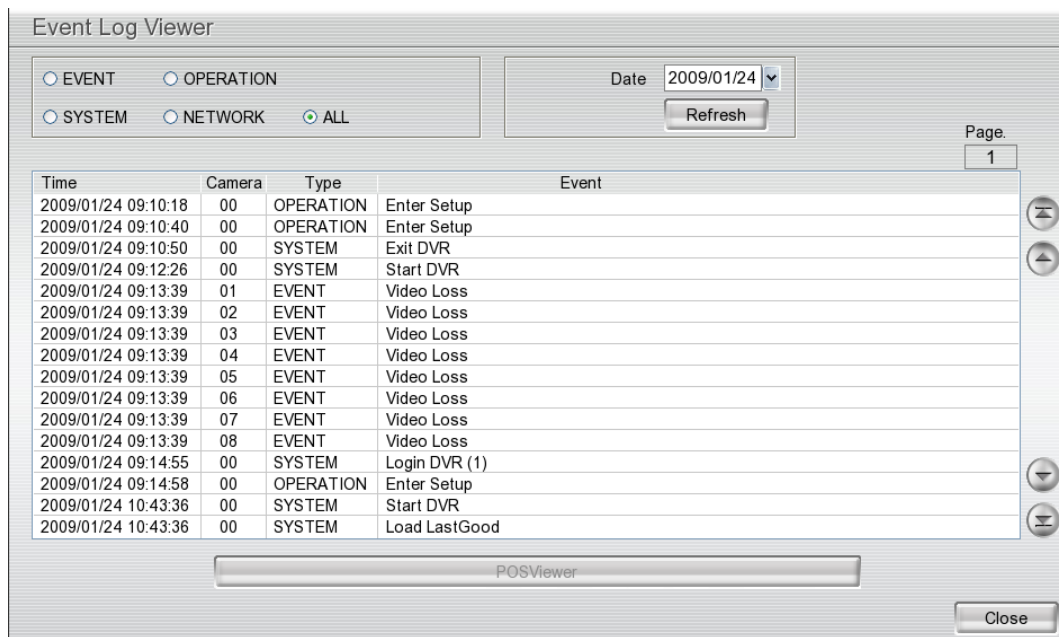



1. Click the **Event Log** button on DVR system main interface. The Event log viewer window will show up.
2. Select the **Date** to view.
3. To filter the records, select and click the select button to display **Event, System, Operation, Network** or **All**.
4. Use the scroll button to go next, previous, first, or last page of event list.
5. To find event log by keyword, enter keyword in **Find Text** column and click **Search**.
6. The events list which display on the screen can be saved as text file format. To save the events list, click **Save** button.

2.4 To Playback the Recorded Video

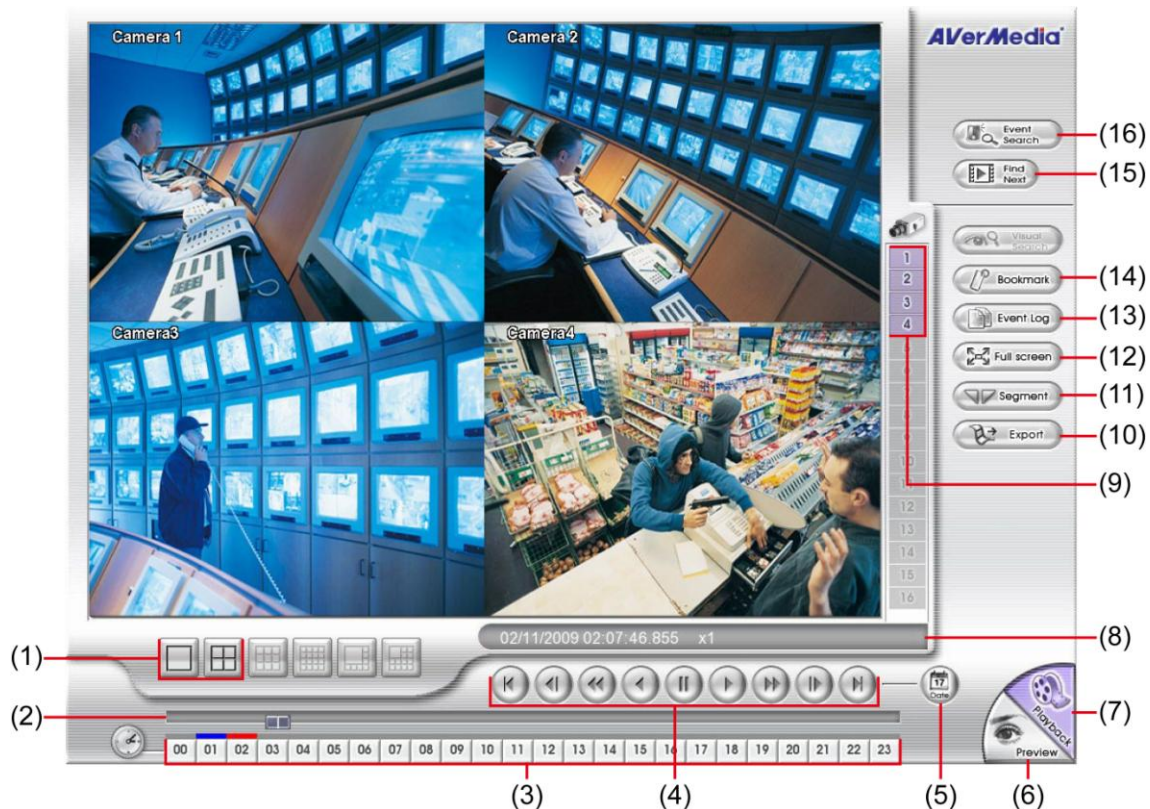
To switch in Playback mode, click **Playback** button at the lower right corner of Preview mode user interface.



Name	Function
(1) Split Screen Mode	Select from 2 different split screen type to playback the recorded video file of all the camera or one camera on a single screen.
 (2) Progress bar	When you are in single screen mode, Right-click and Drag a square on the area you want to enlarge. Right-click on screen again will back to normal view. Show the progress of the file being played. You may move the bar to seek at any location of the track.
(3) Hour Buttons	Select and click to playback the recorded video file on the specific time frame.
 (4) Playback Control Buttons	The Hour buttons represent the time in 24-hour clock. The blue bar on top of the hour button indicates that there is a recorded video file on that period of time. While the red bar indicates that you are currently viewing the recorded video file. From left to right order: Begin: Move at the beginning of the recorded video file. Previous: Go back to the previous frame. Slower: Play the recorded video file at the reduce speed from 64x, 32x, 16x, 8x, 4x, 2x, 1x, 1/2x, 1/4x. Rewind: Wind back the recorded video file. Pause: Briefly stop playing the recorded video file. Play: Play the recorded video file. Faster: Play the recorded video file at the speed of 2X, 4X, or 8X Next: Go to the next frame. End: Go to the end of the recorded video file.

Name	Function
------	----------

(5) Date Select the date on the calendar and the time to start playing the recorded video file.

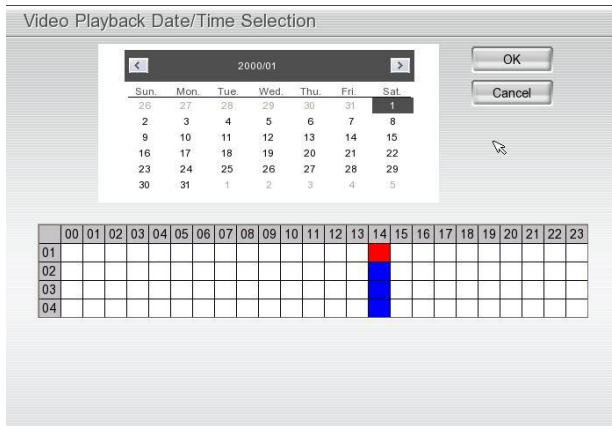

i The numbers from 00 to 23 represent the time in 24-hour clock. The numbers from 01 to 04 represent the camera ID. The blue colored column indicates that there is a recorded video file on that period of time. While the red colored column indicates on where to start playing the recorded video file.

(6) Preview Switch to Preview mode.

(7) Playback Switch to Playback mode to view the recorded video file.

(8) Status bar Display the recorded date, time and play speed.

(9) Camera ID Show the number of cameras that are being viewed. When you are in single screen mode, click the camera ID number to switch and view other camera.

(10) Export Export includes Snapshot, Output Video Clip, and Backup function.

- **Snapshot:** Capture and save the screen shot in *.jpg format.
- **Output Video Clip:** Save the segmented file in *.dvr format to external USB storage device (see also [Chapter 2.4.1](#)).
- **Backup:** Save the playback file to USB device or DVD-ROM disk

(11) Segment Keep a portion of the recorded video (see also [Chapter 2.4.1](#)).

(12) Full screen View in full screen. To return, press the right button of the mouse or ESC on the keyboard or click the arrow icon.



When you switch to full screen in multiple-screen mode, Left click to toggle to only display one of the video in the multiple-screen mode or all.

(13) Event log Show the record of activities that take place in the system. To filter the records, select and click the option button to only display Event, System, Operation, Network or All.

(14) Bookmark Mark a reference point when reviewing the recorded video file to which you may return for later reference (see also [Chapter 2.4.2](#)).

Name	Function
(15) Find Next	Search for the next event or changes in the motion detector frame. You can use this when you are using Event Search function.
(16) Event Search	Search from the recorded activities that were recorded in event log (i.e., Sensor, Motion, Video Loss)(see also Chapter 2.4.3)

2.4.1 To Cut and Save the Wanted Portion of the Recorded Video

1. Use the Playback Control buttons or drag the bar on the playback progress bar and pause on where you want to start the cut. Then, click **Segment** to set the begin mark.



2. Use the Playback Control buttons or drag the bar on the playback progress bar and pause on where you want to end the cut. Then, click **Segment** to set the end mark. To cancel segmentation or set the segment marks from the start, click **Segment** button again.



3. Click **Export > Output Video Clip** button to save the wanted portion.
4. In the **Save As** dialog box, locate on where user wants to save the file, type the filename, and select the video format.

2.4.2 To Bookmark a Video Section

1. Click **Bookmark** button
2. In the Bookmark dialog box, you may do the following:
 - **Add** to create the new reference mark in the bookmark list.
 - **Edit** to change the mark description.
 - **Delete** to remove the selected reference mark in the list.
 - **Delete All** to remove all the reference marks in the list.
 - **Exit** to close Bookmark dialog box.
3. Select and click one in the bookmark list to review the file.

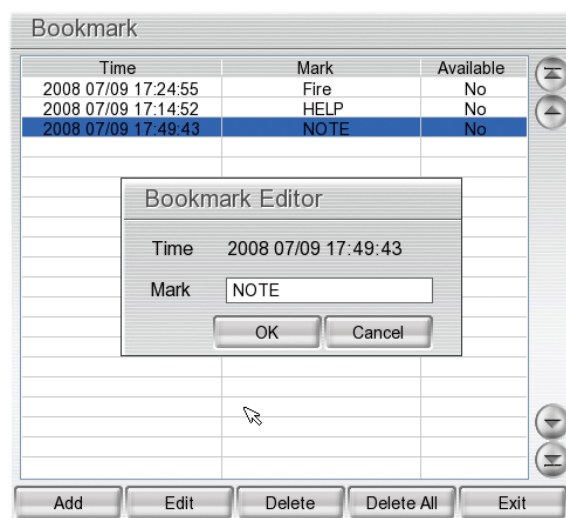

2.4.3 Using the Event Search

1. Click on the video screen on where you want to search.
2. Click **Event Search**. The Event Search Setting dialog box would appear on the screen.
3. In the Event Search Setting dialog box, check the type of condition you want to search. Then, click **OK** to start searching. The video search would stop at the frame that matches the condition. To keep on searching click **Find Next** () button.
4. You may also set to search and list all the result. Set the **Begin Time** and **End Time**. Set the **Searching Interval** time for in a period of time won't list out the same events. Then, click **OK** to start searching.



The DVR system will set the date of **End Time** at 3 days later of Begin Time automatically. If event data are less than 3 days, the DVR system will set End Time at current date. Time of End Time is adjustable.

5. When the Event list appear, click and select the item you want to view.

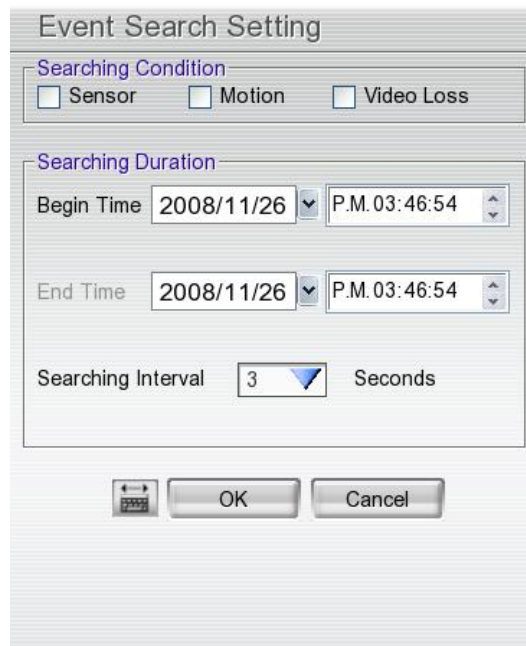

The image shows a screenshot of the 'Event Search Setting' dialog box. It has a title bar with the text 'Event Search Setting'. Below the title bar, there are two sections: 'Searching Condition' and 'Searching Duration'. The 'Searching Condition' section has three checkboxes: 'Sensor', 'Motion', and 'Video Loss', all of which are currently unchecked. The 'Searching Duration' section has two rows of time selection. The first row is for 'Begin Time', with a date dropdown set to '2008/11/26' and a time dropdown set to 'P.M. 03:46:54'. The second row is for 'End Time', also with a date dropdown set to '2008/11/26' and a time dropdown set to 'P.M. 03:46:54'. Below these, there is a 'Searching Interval' section with a dropdown menu set to '3' and the unit 'Seconds'. At the bottom of the dialog box, there are three buttons: a 'Find Next' button with a right-pointing arrow and a magnifying glass icon, an 'OK' button, and a 'Cancel' button.

Chapter 3 Customizing the DVR System

In the Preview screen mode, click **Setup** () button to customize your DVR. Enter the ID and password to authenticate (default ID is **superuser** and password is **111111**).

When the DVR configuration setup selection appears, select and click the buttons you want to change the setting.



3.1 Basic Setup Mode

In default, the setup mode is Advance Setup mode. User can click **Switch to Basic setup** for a quick system setup.



The Basic System Setup window will show up as below shown:

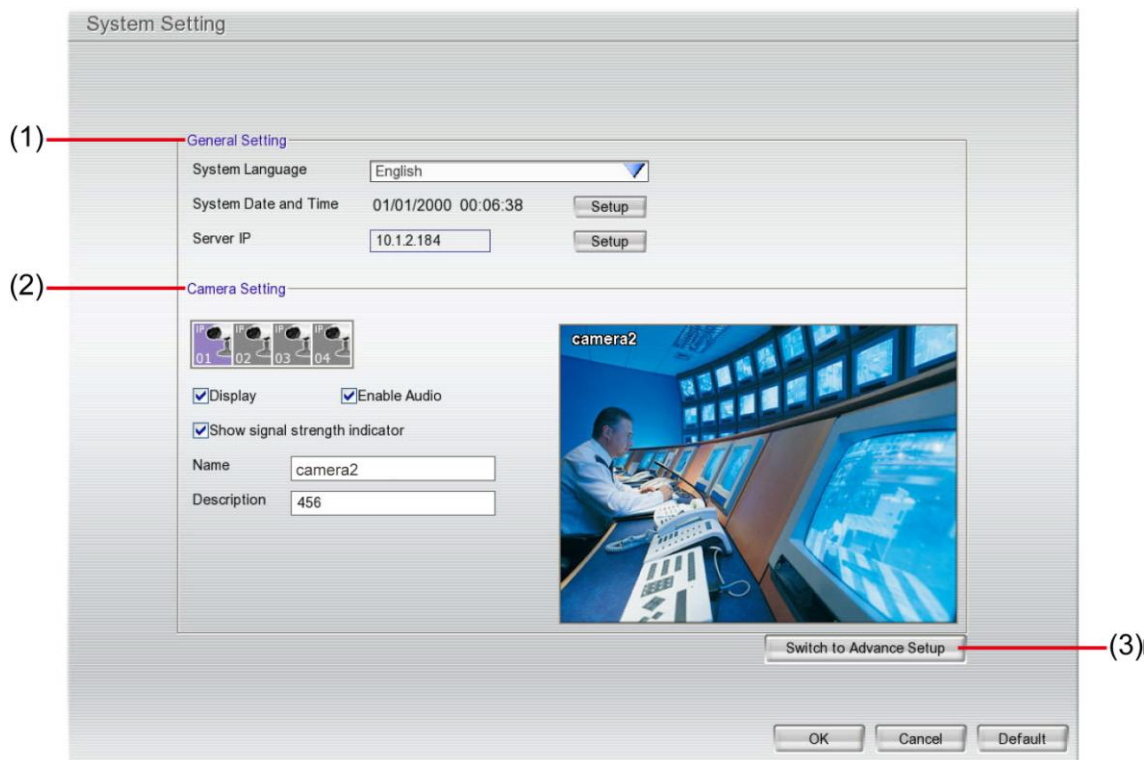

(1) General Setting

- **System Language:** Select the language of the system that will be used on the dialogs and tool tips.

- **System Date and Time:** Click **Setup** to select the current time and date.
- **Server IP:** Click **Setup** to configure the IP mode of the DVR system.

- **Using the following IP address:** Assigns an IP address for the DVR system. Fill in the IP related parameters in **IP information** section.
 - **IP:** Assign a constant IP address which a real IP address gives from ISP to DVR system.
 - **Mask:** It is a bitmask used to identify the sub network and how many bits provide room for host addresses. Enter the subnet mask of the IP address which user has assigned to DVR system.
 - **Gateway:** A network device acts as a passageway to internet. Enter the network gateway IP address
 - **DNS:** Domain Name Server translates domain names (such as www.abb.com.tw) to IP addresses. Enter the IP address of DNS if it is available.
 - **MAC Address:** An identifier hardware address of DVR unit that is assigned by the manufacturer for identification. User don't need to fill in, it will generated by system automatically.
- **Obtain an IP automatically (DHCP):** Assign the IP address by local DHCP server to DVR system.
- **PPPOE:** Point-to-Point Protocol over Ethernet is a network protocol for encapsulating PPP frames in Ethernet frames. It is used mainly with ADSL services. If your network is using ADSL service connecting to internet, and then, select PPPOE mode. Enter **User ID** and **Password** that is given by your ISP for PPPOE connecting authority.
- **DDNS:** DDNS (Dynamic Domain Name Service) is a data query service mainly used on the Internet for translating domain names into Internet addresses. Users can register their own domain name on <http://ddns.avers.com.tw>. (See [Appendix A](#))
 - **Domain Name**
Enter the domain name that user has registered.
 - **Password**
A password use to access DDNS that user has setup when register the domain name
 - **DDNS Server Name**
Select your DDNS server. The default only has one DDNS server now. It may provide more DDNS in future.
 - **DDNS Server Port**
Fill in the port that connects to DDNS server. Default is 1053.

(2) Camera Setting

Select the camera number you want to configure.

- **Display**
Enable/disable to show the video. Even if the video of the selected camera is hidden you can still

record the video and preview it in playback mode.

- **Enable Audio**
Enable/disable audio of the camera.
- **Show signal strength indicator**
To display the Wi-Fi signal strength on surveillance screen.
- **Name**
Change the camera name
- **Description**
Add a short comment

(3) Switch to Advance Setup

Click to switch the setup mode to advance mode (see also [Chapter 3.2](#))

3.2 System Setup

In the System Setting dialog box, click **OK** to accept the new settings, click **Cancel** to exit without saving.

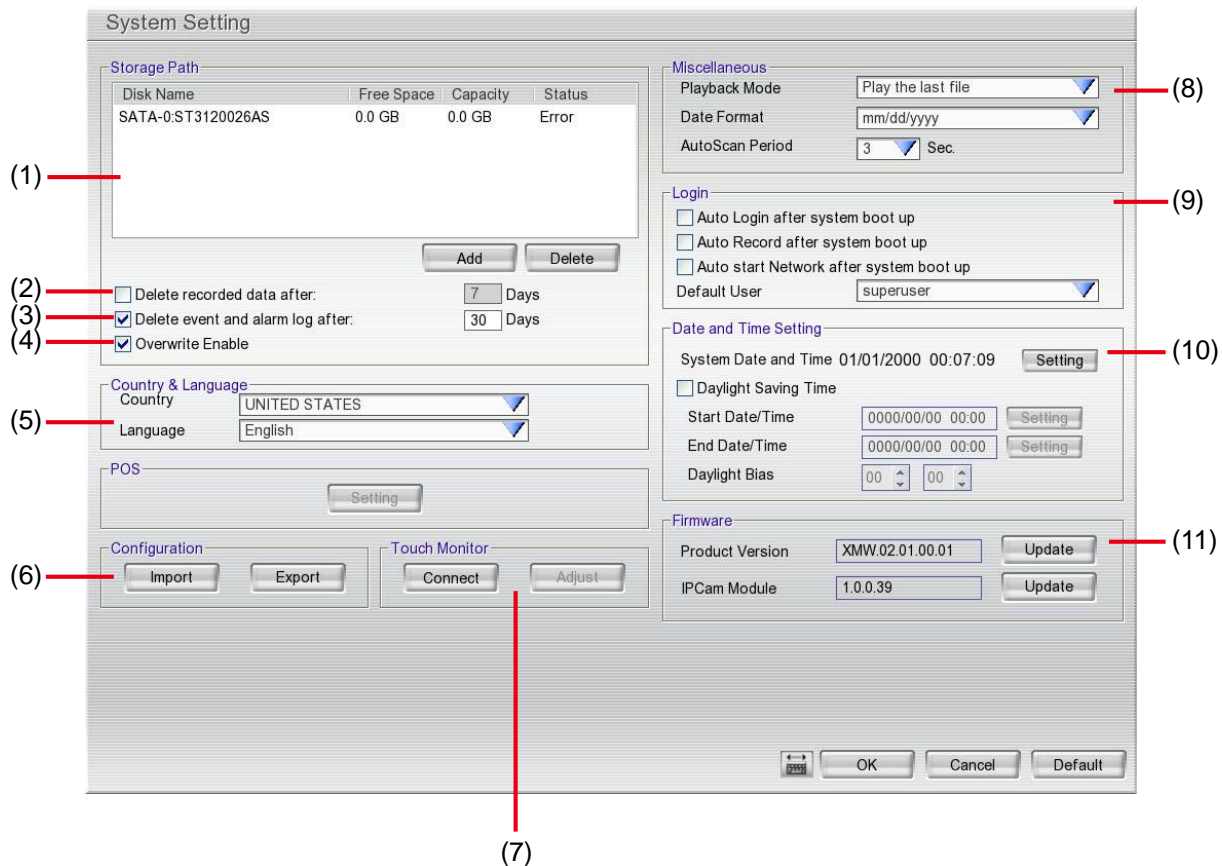

(1) Storage Path

Set the HDD on where to save the data. In case you have more than one storage device, the system automatically saves the data to the next storage device. To insert another storage device, click **Add** and select the storage path. To remove the selected path, click **Delete**. If the hard disk is the first time for DVR system, please format the hard disk before starting to use it. To format the hard disk, select the hard disk and **Format Type**, and then, click **Format** button.

(2) Delete recorded data after

If you want the system to automatically erase the data after a certain days, enable the **Delete recorded data after** check box and enter the number of days in **Days** text box.

(3) Delete event and alarm log after

If you want the system to automatically erase the event and alarm log after a certain days, enable the **Delete event and alarm log after** check box and enter the number of days in **Days** text box.

(4) Overwrite Enable

When there is not enough free space to record one hour data, the system automatically replaces the

oldest data.

(5) Country & Language

Select the location of the DVR unit and customize the system to display the tool tips and dialogs based on the selected language. Default language is in English.

(6) Configuration

Backup a copy of all the settings and allows you to regain the same settings back. To save the current settings, click **Export**. To replace the settings with the one you have saved, click **Import**.

(7) Touch Monitor

When DVR server is connected with touch monitor, user needs to adjust touch monitor in order to work normally.

1. Connect the touch monitor with DVR server.
2. Turn on the DVR server and touch monitor power.
3. Select **Setup** → **System** → **Touch Monitor** → **Adjust**.
4. The adjusting window will show up.

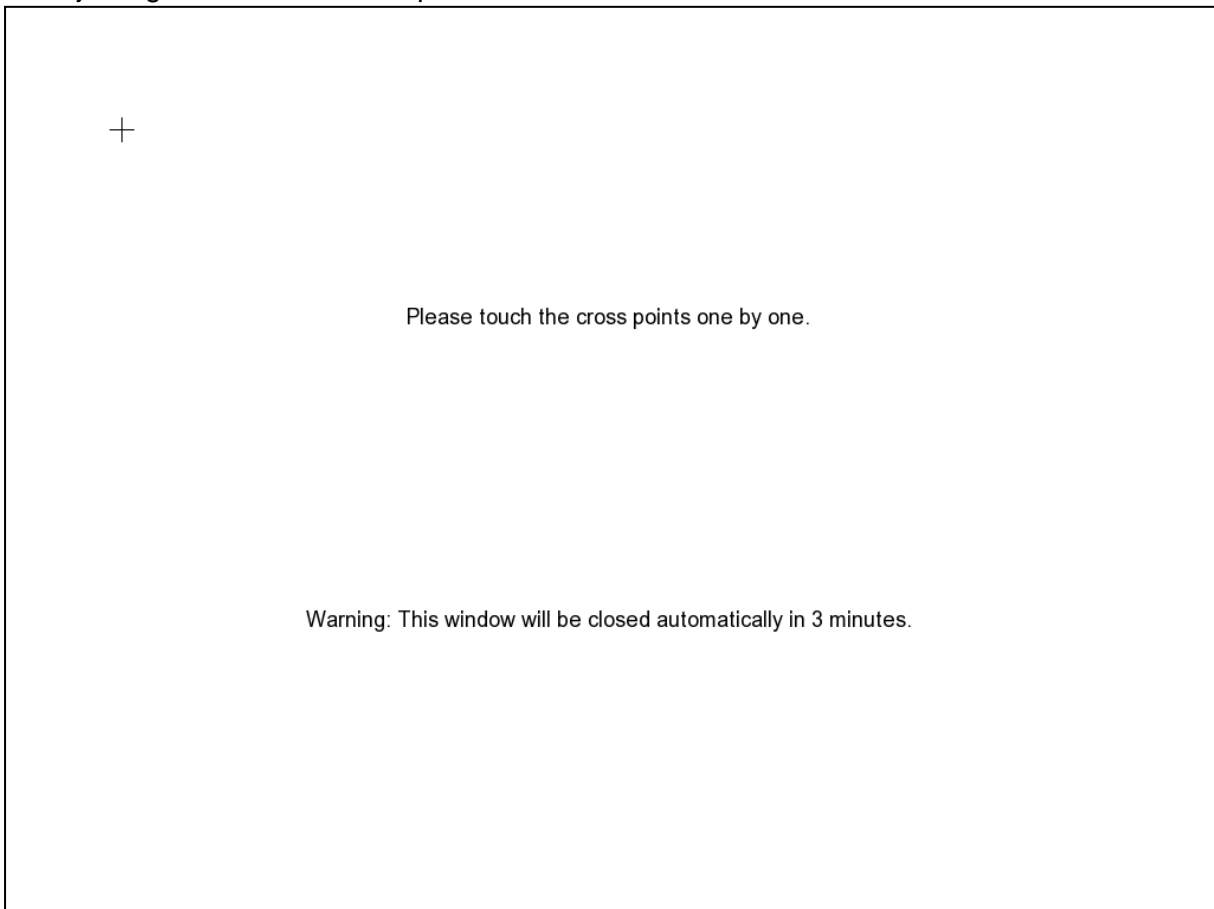

5. Click **+** one by one to complete the adjustment.
6. To disconnect touch monitor, click **Disconnect** button first, and then, turn off the power of touch monitor and remove the connection between DVR server and touch monitor.

(8) Miscellaneous

- **Playback mode:** Select the mode of playback the video.
 - **Select date and time:** Select the date and time which user wants to playback.
 - **Play the last file:** Automatically playback the video from the last hour
 - **Instant Playback:** Automatically playback the video which has just recorded
- **Date Format**
Select the date format which wants to display in select date and time playback mode
- **Auto Scan Period**
Set the time gap of the Auto Scan function from 3 to 10 seconds. This automatically switches to the next video in cycle depending on the set time gap.

(9) Login

Enable the conditions in Login section you want the system to automatically carry out.

- **Auto Login after system boot up**
Execute the DVR when the operating system is started.
- **Auto Record after system boot up**
Automatically start video recording when the DVR is executed.
- **Auto start Network after system boot up**
Automatically start network connection when the DVR is executed.
- **Default user**
Automatically log in to the selected default user when the DVR is executed.

(10) Date and Time Setting

Adjust the DVR system time and date. Click **Setting** to select the month, date, hour, and minute.

Mark **Daylight saving** check box to enable daylight saving function. And then, select the **Start** and **End Date/Time** by click **Setting**.

Daylight Bias: Assign a time that it is for daylight saving time offset in your time zone. For example: if the time zone is in U.S. Eastern, the time offset is 1 hour.

(11) Firmware

- **Product Version Update:** Upgrading the firmware of DVR system.
 1. Click **Update** button, a **Firmware Upgrade** window will show up.



2. Save the firmware on root directory of USB disk. And then, plug USB disk into DVR unit.
3. Select the USB disk if there is more than one USB disk from drop down list. The DVR unit will auto detects the firmware.
4. Click **OK** to start upgrading.

- **IPCam Module Firmware Update:** Update firmware of IP camera.
 1. Click **Update** button, a **Firmware Upgrade** window will show up.



2. Save the firmware on root directory of USB disk. And then, plug USB disk into DVR unit.

3. Select the USB disk if there is more than one USB disk from drop down list. The DVR unit will auto detects the firmware.
4. Click **OK** to start upgrading.

3.3 Camera Setup

The DVR system supports 4 Wireless IP camera connections. Click **Default** will back to the factory default value.

3.3.1 To Setup the Wireless IP Camera

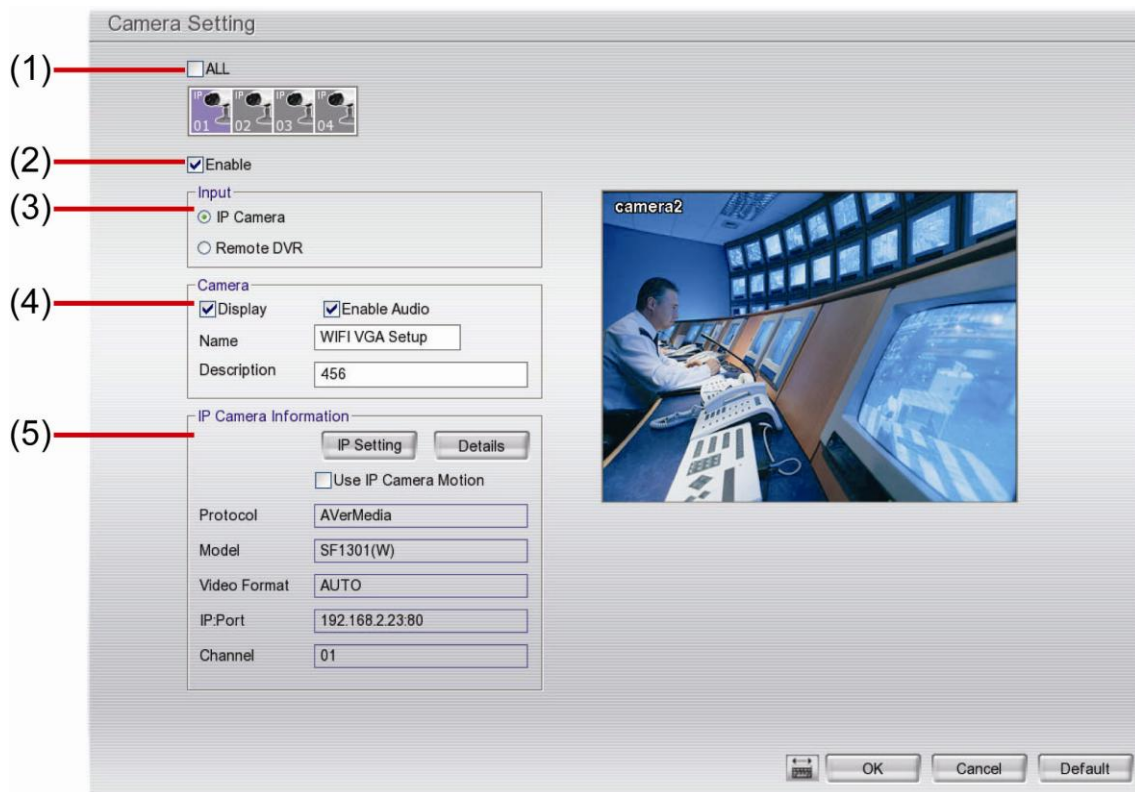

(1) Camera Icons

Select the camera number you want to view. To enable/disable all cameras, click **ALL** check box.

(2) Enable

Set to enable/disable the selected camera. When there is no video source on the camera, we suggest disabling it so that the system won't detect it as video loss error.

(3) Input

Select the camera type as **IP Camera**.

(4) Camera

- **Display**
Enable/disable to show the video. Even if the video of the selected camera is hidden you can still record the video and preview it in playback mode.
- **Enable Audio**
Enable/disable audio of the camera.
- **Name**
Change the camera name
- **Description**
Add a short comment

(5) IP Camera Information

To setup IP camera and display current IP camera information.

- **Use IP Camera Motion:** Mark to enable the motion detected function if the IP camera has supported. Once this function has enabled, the motion detection will based on the IP camera has supported.
- **IP Setting:** Click **IP setting** to view IP camera's detail information. User can view current connected wireless IP camera information such as **Protocol**, **Model**, **Video Format**, **Channel**, and **IP Camera Site**(IP address of IP camera). If wireless IP camera has enabled the authentication, user can mark

Authentication check box and enter the **ID** and **password** of the IP camera. The **URL** is not supported in here.

To exit the IP Camera Settings windows, click **OK** to save the changes and exit. Click **Exit** will not save any changes and exit.

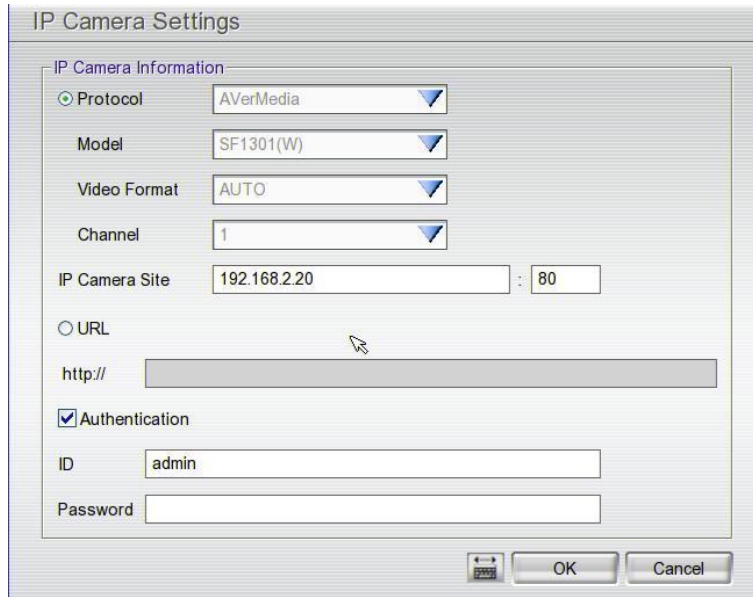

- **Detail:** To adjust IP camera parameters, click **Detail**. Click **Default** will back to the factory default value.

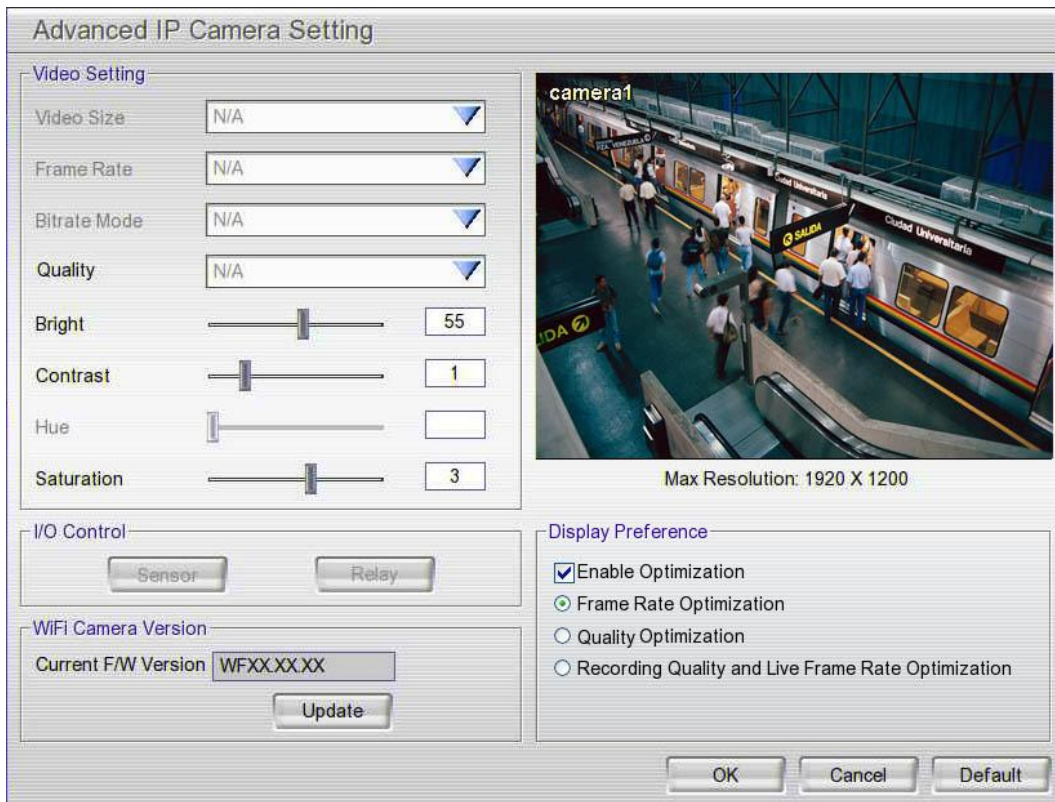

Mark the **Enable Optimization**, the **Video Setting** of the IP camera will automatically set by system pre-set parameters. User can choose three different type of optimization setting – **Frame Rate Optimization**, **Quality Optimization**, or **Recording Quality and Live Frame Rate Optimization**.

If user doesn't want to use the optimization parameters, user can adjust the **Video Size**, **Frame Rate**, **Bitrate Mode**, **Quality**, **Bright**, **Contrast**, and **Saturation** individually.

- ✓ **I/O Control:** The I/O control is not supported in here.
- ✓ **WIFI F/W Version:** The function is not supported in here.

3.3.2 To Setup Camera from the Remote DVR

User can add the camera from another DVR through the network.

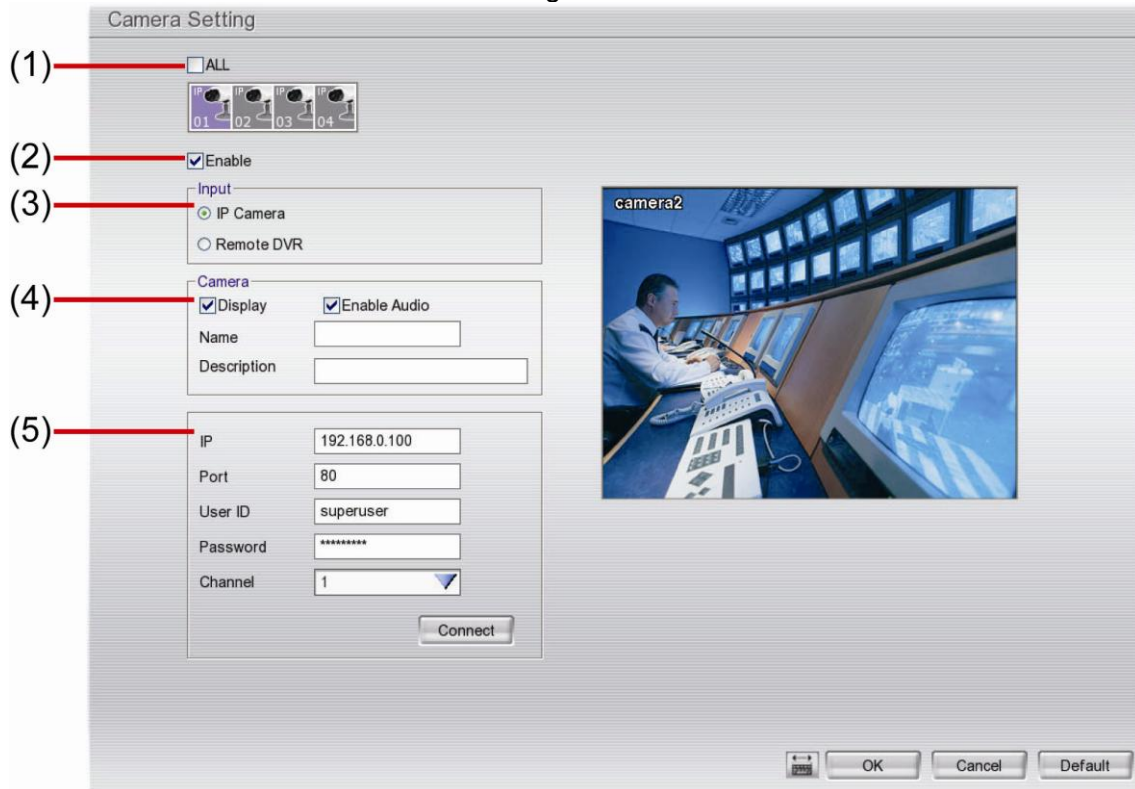

(1) Camera Icons

Select the camera number you want to view. To enable/disable all cameras, click **ALL** check box.

(2) Enable

Set to enable/disable the selected camera. When there is no video source on the camera, we suggest disabling it so that the system won't detect it as video loss error.

(3) Input

Select the camera type as **Remote DVR**.

(4) Camera

- **Display**
Enable/disable to show the video. Even if the video of the selected camera is hidden you can still record the video and preview it in playback mode.
- **Enable Audio**
Enable/disable audio of the camera.
- **Name**
Change the camera name
- **Description**
Add a short comment
- **IP**
Enter the IP address of the camera
- **Port**
The port for connection
- **User ID**
Enter the user id that for connecting authority
- **Password**
Enter the password that is for connecting authority
- **Channel**
Select the channel of connected camera

- **Connect**

Click to connect the camera when all configurations are set.

3.4 Recording Setup

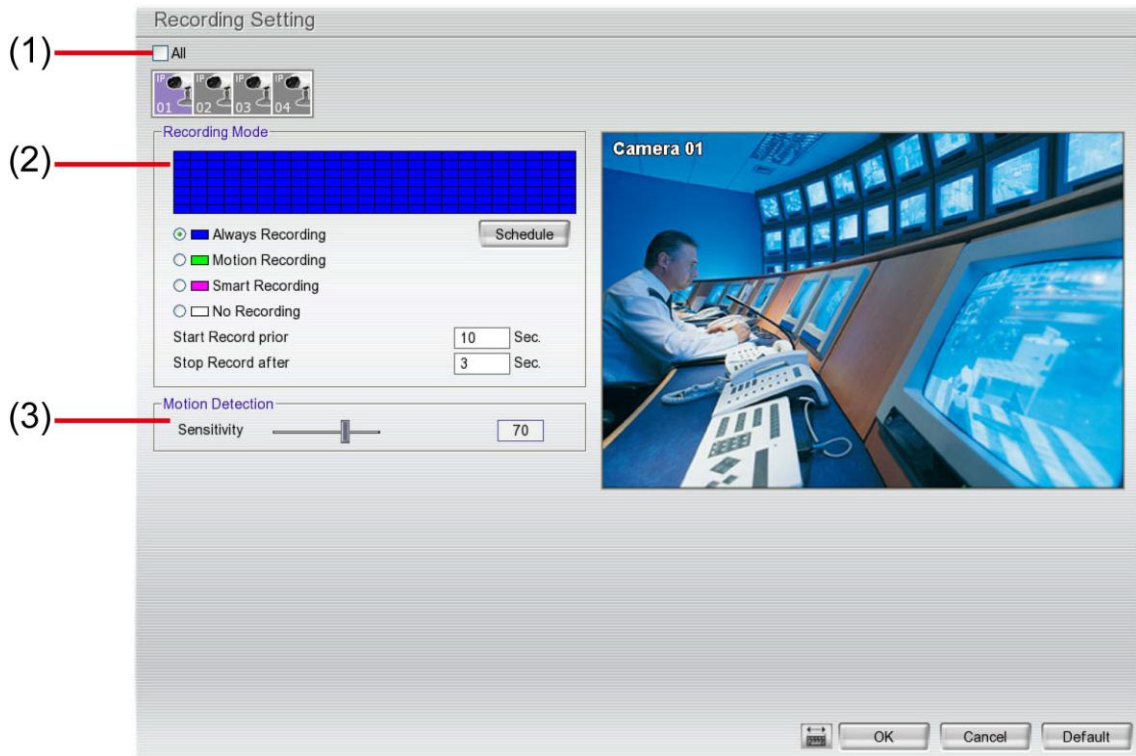

(1) Camera Icons

Select the camera number you want to set the recording setting. To select all the cameras, enable the **ALL** check box. To select more than one camera, **Right click** on the camera icon. To select one camera only, **Left click** on the camera icon. The camera icon turns purple when it is selected.

(2) Recording Mode

The horizontal blocks from 00 to 23 represent the time in 24-hour clock and the vertical block 1 to 7 represent the day in the week block (Sunday to Saturday). To record in full 24 hours and 7 days a week, select the recording mode and click the button. If you want to only record at a particular time or day, click **Schedule** button and select the **Recording Mode**, and then click on the time or day blocks. When the system starts recording a red triangle mark would appear at the upper left corner of the screen. The recording modes are listed below:

- **Always Recording**
Record the video from the selected camera and save it to the designated storage device
- **Motion Recording**
Start recording the video from the selected camera only when the system detects movement. Once a motion is detected, the system automatically saves the previous frames and stop based on the **Start Record Prior** and **Stop Record After** settings.
- **Smart Recording**
Automatically switch to recorded at the maximum frame rate setting once a motion is detected and if there is no motion, it records at the minimum frame rate setting.
- **No Recording**
The system won't do any recording.

(3) Motion Detection

Adjust the sensitivity of the motion detection. The higher the value, the finer the sensitivity is detected. When it detects a motion, a green triangle mark would appear at the upper left corner of the screen.

3.5 Network Setup

Click **Default** will back to the factory default value.

The screenshot shows the 'Network Setting' window with the following sections and callouts:

- (1) **Server Name**: Text field containing 'EXR6008'.
- (2) **Transmitting Cameras**: Section with an 'All' checkbox and four numbered checkboxes (1, 2, 3, 4), all of which are checked.
- (3) **Main Configuration**: Section containing 'Server IP' (10.1.2.184) and 'Remote Console PORT' (5550), with a 'Setting' button.
- (4) **WiFi Information**: Section containing 'Current WiFi Channel' (CH 02), 'Wireless Module MAC' (00:0e:8e:20:94:c2), and a 'Refresh' button.
- (5) **Remote Upgrade Configuration**: Section with a 'PORT' field set to 5005.
- (6) **WebViewer Configuration**: Section with 'Enable Anonymous Login' checked and 'WebViewer PORT' set to 81.
- (7) **Network Time Synchronization**: Section with 'Time Server' (time.stdtime.gov.tw), 'Time Zone' (GMT+03:00), and 'Automatic synchronize at' (03:00), with a 'Synchronize Time Right Now' button.
- (8) **Other Configuration**: Section with 'Enable White List' and 'Network Bandwidth Limit' checked, and two 'Detail' buttons.

At the bottom of the window are 'OK', 'Cancel', and 'Default' buttons.

(1) Server Name

Assign a name for the DVR unit. Alphabet letters and numbers only.

(2) Transmitting Cameras

Select and click on the camera number in the Transmitting Camera section you want to make it accessible via internet using WebViewer, Remote Console, PDA Viewer and JAVAViewer (still image). To select all the cameras, enable the **ALL** check box.

(3) Main Configuration

Set the DVR IP address and **Remote Console Port**. You need this when accessing DVR server from the remote location via internet. Click **Setting** to setup DVR IP.

The screenshot shows the 'System IP setting' window with the following sections:

- IP Selection**: Radio buttons for 'Using the following IP address' (selected), 'Obtain an IP automatically(DHCP)', and 'PPPOE'.
- IP Information**: Fields for IP, Mask, Gateway, DNS, and MAC Address (00:18:0a:3e:2e:1d).
- PPPOE**: Fields for User ID and Password.
- DDNS**: Checked checkbox, with fields for Domain Name, Password, DDNS Server Name (ddns.avers.com.tw), and DDNS Server Port (1053).

At the bottom are 'OK' and 'Cancel' buttons.

■ **Using the following IP address:** Assigns an IP address for the DVR system. Fill in the IP related parameters in **IP information** section.

- **IP:** Assign a constant IP address which a real IP address gives from ISP to DVR system.
- **Mask:** It is a bitmask used to identify the sub network and how many bits provide room for host addresses. Enter the subnet mask of the IP address which user has assigned to DVR system.
- **Gateway:** A network device acts as a passageway to internet. Enter the network gateway IP

address

- **DNS:** Domain Name Server translates domain names (such as www.abb.com.tw) to IP addresses. Enter the IP address of DNS if it is available.
- **MAC Address:** An identifier hardware address of DVR unit that is assigned by the manufacturer for identification. User don't need to fill in, it will generated by system automatically.
- **Obtain an IP automatically (DHCP):** Assign the IP address by local DHCP server to DVR system.
- **PPPOE:** Point-to-Point Protocol over Ethernet is a network protocol for encapsulating PPP frames in Ethernet frames. It is used mainly with ADSL services. If your network is using ADSL service connecting to internet, and then, select PPPOE mode. Enter **User ID** and **Password** that is given by your ISP for PPPOE connecting authority.
- **DDNS:** DDNS(Dynamic Domain Name Service) is a data query service mainly used on the Internet for translating domain names into Internet addresses. Users can register their own domain name on <http://ddns.avers.com.tw>. (See [Appendix A](#))
 - **Domain Name**
Enter the domain name that user has registered.
 - **Password**
A password use to access DDNS that user has setup when register the domain name
 - **DDNS Server Name**
Select your DDNS server. The default only has one DDNS server now. It may provide more DDNS in future.
 - **DDNS Server Port**
Fill in the port that connects to DDNS server. Default is 1053.

(4) WiFi Information

- **Current WiFi Channel:** Display the channel that is a WiFi IP camera connection.
- **Enable WiFi RF Interference Mitigation:** Mark this for the DVR system to intelligently choose the WiFi channel (the channels may vary that depend on the country region) for the best WiFi signal transmitting performance.
- **Wireless Module MAC:** Display the MAC address of the wireless card that is bundled inside the DVR unit.

(5) Remote Upgrade Configuration

A port is using for the remote firmware upgrade through network.

(6) WebViewer Configuration

Activate **Enable Anonymous Login** to remotely access the DVR server without the need of password. Fill in the **WebViewer PORT** for remote accessing connection.

(7) Network Time Synchronization

Adjust the DVR system time same as network time server. Fill in the **Time Server** IP address or domain name and select the **Time Zone**. User can enable **Automatic Synchronize at** to set automatic synchronize time on a daily basis. Or, user can click **Synchronize Time Right Now** to adjust time right away.

(8) Other Configuration

- **Enable White List**
An access permit list for the remote accessing of DVR server. Enter the IP address and click **Add**. Or, enter a range of IP address and click **Add**. To delete the IP from the list, select the IP and click **Delete** button. To reset the input, click **Clear** button.

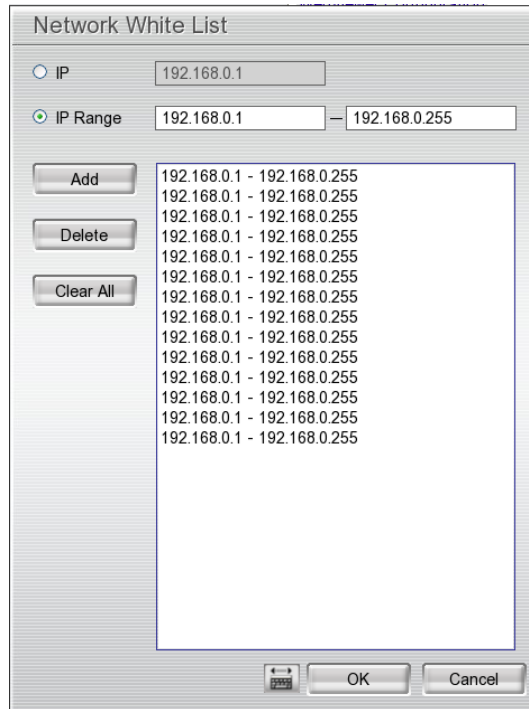

- **Network Bandwidth Limit**

By Channel: Set the network bandwidth by each channel.

All: Set the total network bandwidth consumption limit.

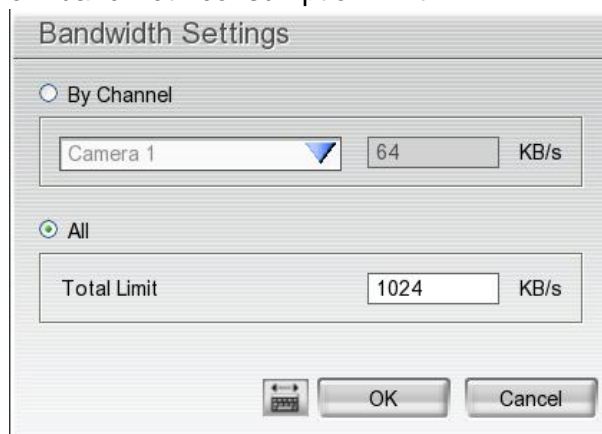

3.6 Schedule Setting

Schedule to record, enable network, reboot and disable alarm of all the cameras either weekly or one time. The number from 00 to 23 represent the time in 24-hour clock. The left most column display the days in a week.

Schedule Setting

2008/07

Sun.	Mon.	Tue.	Wed.	Thu.	Fri.	Sat.
29	30	1	2	3	4	5
6	7	8	9	10	11	12
13	14	15	16	17	18	19
20	21	22	23	24	25	26
27	28	29	30	31	1	2
3	4	5	6	7	8	9

Record

Weekly

One Time

Remove

	00	01	02	03	04	05	06	07	08	09	10	11	12	13	14	15	16	17	18	19	20	21	22	23
Sun																								
Mon																								
Tue																								
Wed																								
Thu																								
Fri																								
Sat																								

Save Clear All OK Cancel

To Set the Schedule Setting:

- Select the date in the calendar. Use ◀ and ▶ buttons to shift the calendar to the left or right.
- Select the condition you want to schedule in the drop down list.
 - **Record**
Activate all the cameras to start video recording at the set time based on the Recording setting
 - **Enable Network**
Activate DVR remote system to access at the set time. After the appointed time, the Network function will be disabled. If the Network function is already enabled, the Network function will not be disabled when the appointed time has ended.
 - **Reboot**
Restart the PC at the appointed time.
 - **Disable Alarm**
Deactivate the alarm at the set time temporarily.
- Set the schedule as weekly or one time. Click ⊙ to make a selection.
- Click on the blocks to set the schedule or click **All** to select all. To un-select the specific schedule blocks, click the **Remove** and click blocks to un-select. To store the setting, click **Save**. To remove the settings, click **Clear**.
- To end Schedule Setting, click **OK** to exit and accept the setting and **Cancel** to exit without saving the setting.

3.7 Backup Setup

In the Backup Setting dialog box, the number from 00 to 23 represent the time in 24-hour clock. The numbers from 01 to 16 represent the camera number. When you back up the file, you may find Qplayer application included in the backup folder. User need to execute the Qplayer installation on PC for playback. (see also [Chapter 3.7.1](#))

The screenshot shows the 'Backup Setting' dialog box. At the top left is a calendar for January 2000. To its right are two input fields for 'Require Space' and 'Free Space', both showing '0.00 MB'. Below these are 'Rescan Device' and 'Backup Now' buttons. A checkbox labeled 'Delete recorded files after Backup' is present. Below that is a 'Save path' dropdown menu showing 'N/A' and a 'Folder Name' text box containing 'Backup'. At the bottom is a table for selecting camera and time. The table has columns for time (00-23) and rows for camera (01-04). The cells for camera 01 and 02 at time 11 and 12 are highlighted in blue. At the very bottom are 'All', 'Clear All', and 'Exit' buttons.

	00	01	02	03	04	05	06	07	08	09	10	11	12	13	14	15	16	17	18	19	20	21	22	23
01																								
02																								
03																								
04																								

1. Select the date of the recorded file in the calendar you want to backup. Use ◀ and ▶ buttons to shift the calendar to the left or right.
2. In the table below, click on the blue block to select the recorded file or click camera (01~04) or time (00~23) to select the whole row or column. The blue block turns red when it is selected. The block that appears in white doesn't have data. If you want to set the specific time, right-click on the selected block. Then, set the time to start and end.
3. Check the space need for backup beside the calendar. Click **Rescan Device** to calculate the space for backup.
 - **Require Space**: Show the total size of the backup file.
 - **Free Space**: Show the available storage space
4. If you do **NOT** want to keep the recorded file in the storage folder, enable **Delete files after Backup** check box.
5. Select the backup device – USB disk or DVD-ROM device.
6. DVR system will give **Folder Name** automatically.
7. Click  to start archiving the selected file.



3.7.1 Using QPlayer to Playback Backup Video

You can playback the backup files using QPlayer applications on the PC. When you back up the recorded file, QPlayer applications are automatically included in the backup folder. With QPlayer, it is the same as in Playback mode and supports different split screen types to view all the video at the same time. The only difference is that there are no Preview and Playback buttons.

To run the application, go to backup folder and double-click **install_player** to intall QPlayer. After installation, double-click **QPlayer** icon on the PC desktop.



Name	Function
(1) Split Screen Mode	Select from 6 different split screen type to playback the recorded video file of all the camera, or one camera over the other or alongside on a single screen.
i	<ul style="list-style-type: none"> - If there are only 4 cameras, you won't be able to switch to 8, 16, and 13 split screen mode. - To zoom in an area on the screen, Right click and Drag a square on the area you want to enlarge.
(2) Exit	To close the application
(3) Progress bar	Show the progress of the file being played. You may move the bar to seek at any location of the track.
(4) Hour Buttons	Select and click to playback the recorded video file on the specific time frame.
i	The Hour buttons represent the time in 24-hour clock. The blue bar on top of the hour button indicates that there is a recorded video file on that period of time. While the red bar indicates that you are currently viewing the recorded video file.
(5) Playback Control Buttons	<p>Begin: Move at the beginning of the recorded video file.</p> <p>Previous: Go back to the previous frame.</p> <p>Slower: Play the recorded video file at the speed of 1/2X, 1/4X, 1/8X, 1/16X, or 1/32X.</p> <p>Rewind: Wind back the recorded video file.</p> <p>Pause: Briefly stop playing the recorded video file.</p> <p>Play: Play the recorded video file.</p> <p>Faster: Play the recorded video file at the speed of 2x, 4x, 8x, 16x, or 32x.</p> <p>Next: Go to the next frame.</p> <p>End: Go to the end of the recorded video file.</p>

Name	Function
(6) Archive	Select the date on the calendar and the time from 00 to 23 to where to start playing the recorded video file. <ul style="list-style-type: none"> – OPEN FILE: user can open the recorded file from HDD – Day Light Saving: the playback calendar will show the available video records during day light saving time period.
	The numbers from 00 to 23 represent the time in 24-hour clock. The numbers from 01 to 16 represent the camera ID. The blue colored column indicates that there is a recorded video file on that period of time. While the red colored column indicates on where to start playing the recorded video file.
(7) Status bar	Display the recorded date, time and play speed.
(8) Language	Customize the system to display the tool tips and dialogs based on the selected language. By default the language is in English.
(9) Export	Export includes Snapshot, Print, and Output Video Clip function. <ul style="list-style-type: none"> ▪ Snapshot: Capture and save the screen shot either in *.jpg format. ▪ Print: Print the screen shot. ▪ Output Video Clip: Save the segmented file in *.dvr format.
(10) Segment	Keep a portion of the recorded video (see also Chapter 3.7.2).
(11) Full screen	View in full screen mode. To return, press the right button of the mouse or ESC on the keyboard or click the arrow icon.
	
	When you switch to full screen in multiple-screen mode, Left click to toggle to only display one of the video in the multiple-screen mode or all.
(12) Event Log	When backup, the DVR system will include event logs. User can view the record of activities that take place in the system. To filter the records, select and click the option button to only display Event, System, Operation, Network or POS.
(13) Visual Search	Search from a specific camera by Date, Hour, Minute, 10 Seconds and Second. (See also Chapter 3.7.3)
(14) Camera ID	Show the number of cameras that are being viewed. When you are in single screen mode, click the camera ID number to switch and view other camera.
(15) Find Next	Search for the next event or changes in the motion detector frame. You can use this when you are using Intelligent Search or Event Search function.
(16) Event Search	Search from the recorded activities that were recorded in event log (i.e., Sensor, Motion, Video Loss). (See also Chapter 3.7.4)
(17) Intelligent Search	Search the changes in the motion detector frame (See also Chapter 3.7.5).
(18) Audio	Enable/disable volume
(19) De-interlace	To enhance the video quality. Set the de-interlace mode to #1, if you are capturing motionless picture and #2, if it captures lots of movement.

3.7.2 To Cut and Save the Portion of the Recorded Video

1. Use the Playback Control buttons or drag the bar on the playback progress bar and pause on where you want to start the cut. Then, click **Segment** to set the begin mark.



2. Use the Playback Control buttons or drag the bar on the playback progress bar and pause on where you want to end the cut. Then, click **Segment** to set the end mark. To cancel segmentation, click **Segment** button again.







3. Click **Export > Output Video Clip** button to save the wanted portion.
4. In the **Save As** dialog box, locate on where user wants to save the file, type the filename, and select the video format.

3.7.3 To Search Using the Visual Search

1. Click **Visual Search**.
2. In the Visual Search Setting dialog box, select the Camera number and the date. Then click **OK**.



3. When a series of frames appear by date, click on the frame to display another series of frames and search by every Hour of that date, every Minutes of that hour, 10 Seconds, 3 Seconds, and every Second of that minute. Using  and  to go next and last page of time page. To go back last time selection (hour, minute, or second), click . To close event search, click .

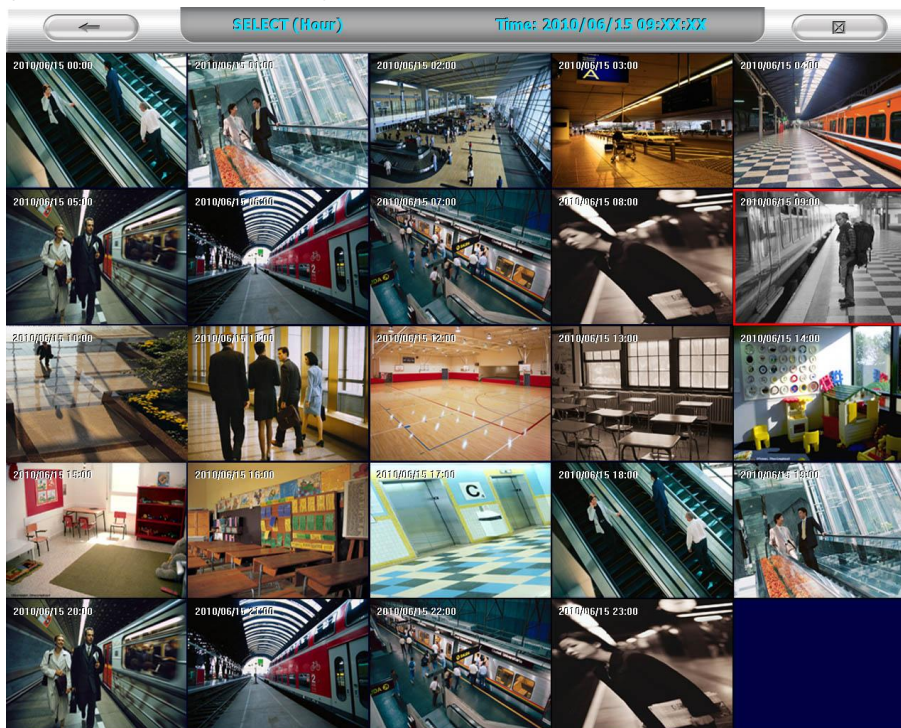

3.7.4 To Search Using the Event Search

1. Click on the video screen on where you want to search.
2. Click **Event Search**. The Event Search text (red) would appear at the lower left corner of the screen.
3. In the Event Search Setting dialog box, check the type of condition you want to search. The video search would stop at the frame that matches the condition. To keep on searching click .
4. You may also set to search and list all the result. In the **Search Duration** section, set the **Begin Time** and **End Time**. Set the **Searching Interval** time that system won't list out the same events in a period of time that user has setup. Then, click **OK** to start searching.
5. When the Event list appear, click and select the item you want to view.

3.7.5 To Search Using the Intelligent Search

1. Click on the video screen on where you want to search.
2. Click **Intelligent Search**. The Intelligent Search text (red) would appear at the lower left corner of the screen.
3. When the Intelligent Search Setting dialog box and motion detector frame appear, you may adjust the sensitivity bar and the motion detector frame size and location. To set motion detector frame size and location, left click and drag on the screen. Then, click **OK** to start searching. The video search would stop at the frame that matches the condition. To keep on searching click . You may also set to search and list all the result. Just check the **List** box. In the **Search Duration** section, set the **Begin Time** and **End Time**. Set the **Searching Interval** time that system won't list out the same events in a period of time that user has setup. Then, click **OK** to start searching.



3.8 Sensor Setting

The I/O device must be installed to use this function.

1. Click the drop-down list and select the sensor ID number.
2. Enter sensor name in **Name** column.
3. The system automatically detects the card and input number. In the **Content** section, enter **Description** of sensor.
4. In the test section, click **Test** to check the sensor status. **Red** is high and **Green** is low.
5. Click **OK** to exit and accept the setting and **Cancel** to exit without saving the setting.

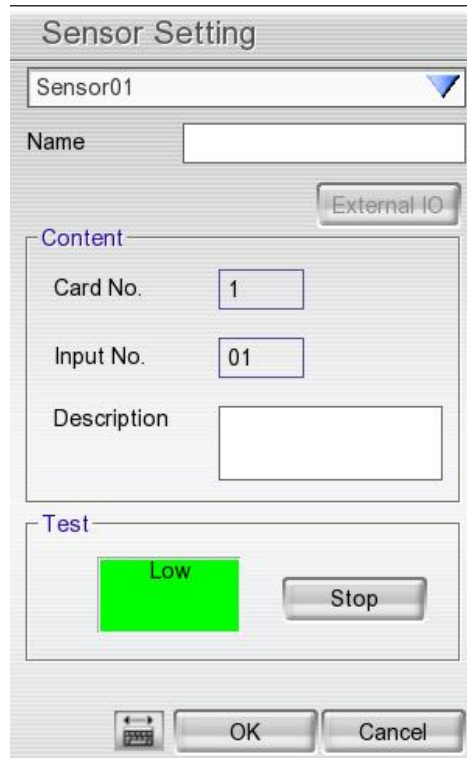

The screenshot shows a dialog box titled "Sensor Setting". At the top, there is a drop-down menu with "Sensor01" selected. Below this is a "Name" label followed by an empty text input field. To the right of the "Name" field is a button labeled "External IO". The dialog is divided into three sections: "Content", "Test", and a bottom control area. The "Content" section contains three fields: "Card No." with the value "1", "Input No." with the value "01", and "Description" with an empty text input field. The "Test" section features a green rectangular indicator with the word "Low" written on it, and a "Stop" button to its right. At the bottom of the dialog, there are three buttons: a small icon button on the left, an "OK" button in the center, and a "Cancel" button on the right.

3.9 Relay Setting

The I/O device must be installed to use this function.

1. Click the drop-down list and select the relay ID number.
2. Enter relay name in **Name** column.
3. The system automatically detects the card and input number. In the Content section, enter **Description** of relay.
4. In the test section, click **Test** to trigger relay. **Red** is high and **Green** is low.
5. Click **OK** to exit and accept the setting and **Cancel** to exit without saving the setting.

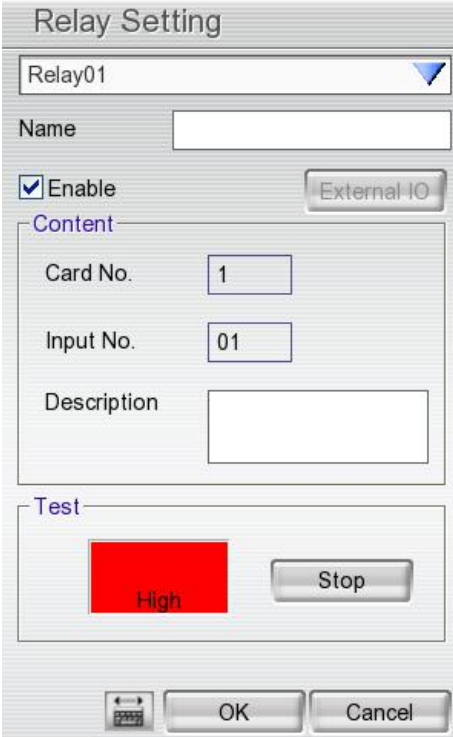

The image shows a 'Relay Setting' dialog box with the following fields and controls:

- A drop-down menu at the top containing 'Relay01'.
- A text input field labeled 'Name'.
- A checked checkbox labeled 'Enable' and a button labeled 'External IO'.
- A section titled 'Content' containing:
 - A text input field labeled 'Card No.' with the value '1'.
 - A text input field labeled 'Input No.' with the value '01'.
 - A text input field labeled 'Description'.
- A section titled 'Test' containing:
 - A red rectangular indicator with the text 'High' inside.
 - A button labeled 'Stop'.
- At the bottom, there are three buttons: a keyboard icon, 'OK', and 'Cancel'.

3.10 Alarm Setting

In the Alarm Setting dialog box, click **Add** to insert and set new alarm setting, click **Delete** to remove the selected alarm setting, click **OK** to exit and save the setting, **Cancel** to exit without saving. Click **Default** will back to factory default value.

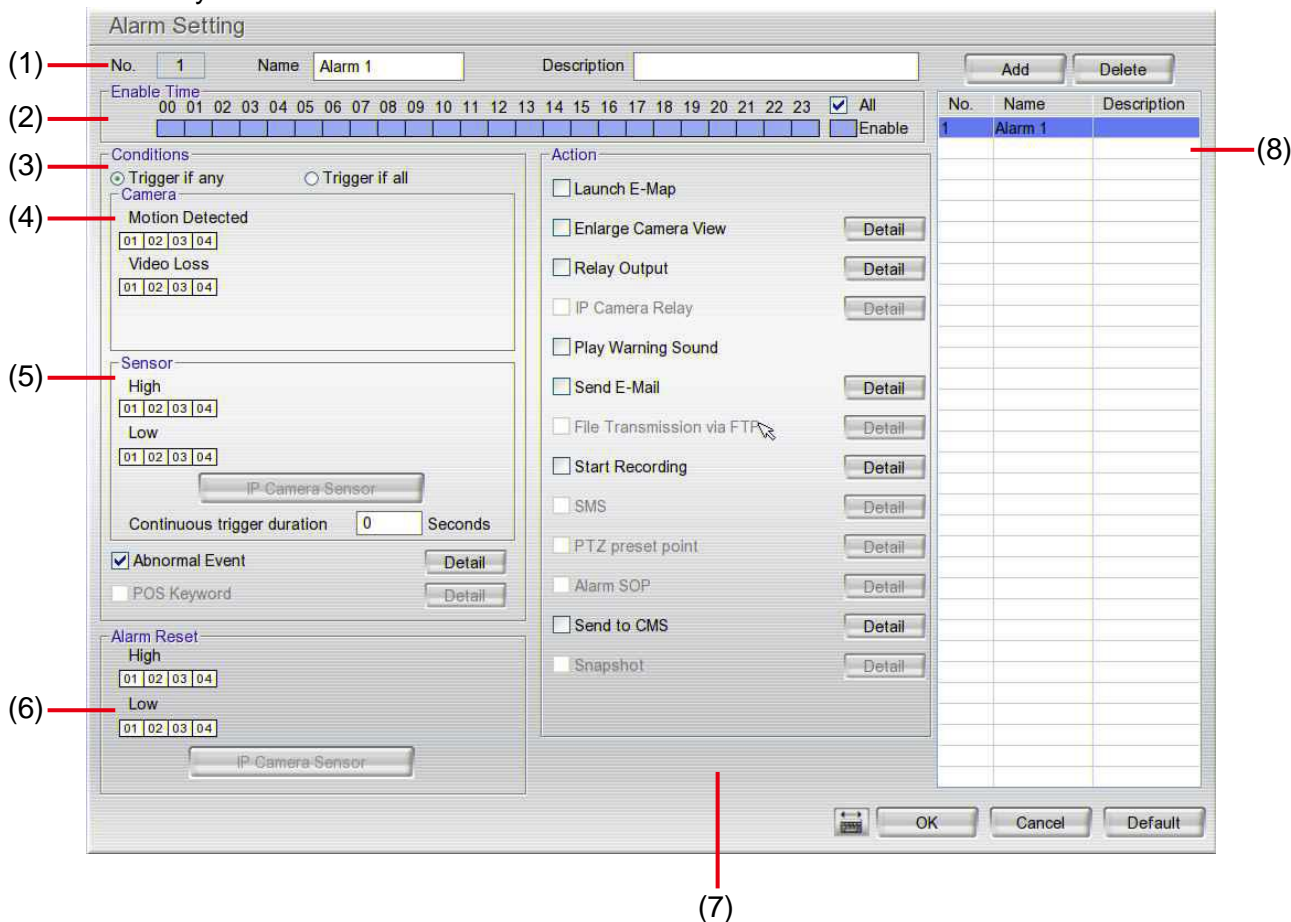

1. Click **Add** to insert and set a new alarm setting. Click the items in the **(8) Alarm Setting List** if you want to modify the alarm setting.
2. In **(1) No./Name/Description** enter alarm name and description. Alarm **No.** will be created by DVR system.
3. In **(2) Enable Time**, the number from 00 to 23 represent the time in 24-hour clock. Select the time and click the block you want to activate or deactivate the alarm function. When it is deactivated the color of the block turns white.
4. In **(3) Conditions**, you can set **“Trigger if any”** to activate if it falls to one of the conditions or **“Trigger if all”** to activate if it falls to all conditions.
5. In **(4) Camera** section, select and click on the camera number (01 to 04) in **Motion Detected** and **Video Loss** to set the condition for the system to alarm.
6. In **(5) Sensor**, select and click on the sensor number to set the condition for the system to alarm. If the sensor normal status is high, set the sensor condition to low.
 - Enable/disable the **Abnormal Event** check box, to set the condition of the event for system to alarm.

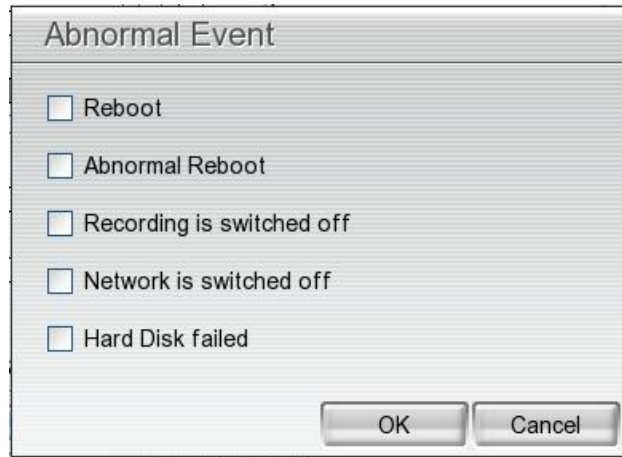

- **Reboot:** when the DVR system reboot without abnormal condition, the system will send out the alarm message.
 - **Abnormal Reboot:** when the DVR system reboot in irregular condition, the system will send out the alarm message.
 - **Recording is switched off:** when the recording has been stopped, the system will send out the alarm message.
 - **Network is switched off:** when the network connection of DVR system is lost, the system will send out the alarm message.
 - **Hard Disk failed:** when the hard disk doesn't work normally, the system will send out the alarm message.
- **Continue trigger duration:** Set a time period that when sensor has been trigger and stay in the same status for that period, then the alarm will be sent out.
7. In **(6) Alarm Reset**, click the camera number to set the reset condition of alarm. Once alarm is reset, all alarm action will stop at the moment. If the sensor normal status is high, set the alarm reset condition to low.
8. In **(7) Action**, you may now set the alarm action for the system to perform when the alarm condition is activated.
- **Launch E-Map:** Display mini E-map screen.
 - **Enlarge Camera View**
Switch to only display video in Preview mode from where the alarm is activated.
 - a. Select the camera from drop down list to specify which camera video to be enlarged on screen when the alarm is triggered.
 - b. **Retrieve time:** set the waiting duration before system switching back to original Preview mode. If the retrieve time is un-mark, the alarm video will keep enlarging until user switch back to Preview mode manually. The retrieve time range is 0~ 600 seconds.

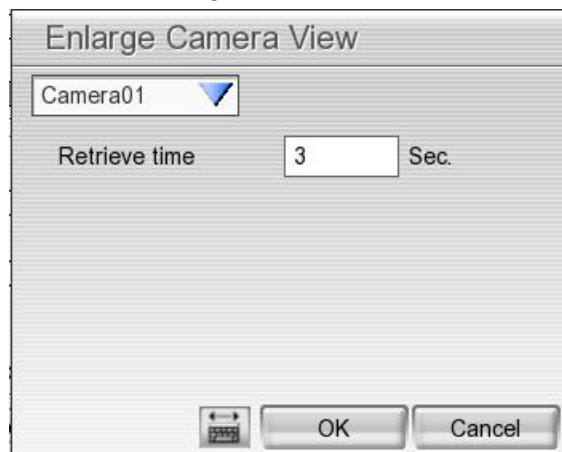

- **Relay Output**

Set to enable/disable the relay operation when the alarm is activated and to extend additional time in second before it stops the relay operation.

1. Beside the Relay Output check box, click **Detail**.
2. In the Alarm Relay dialog box, select from the available relay list and in the ON column, set to enable/disable the relay operation when the alarm is activated.
3. In the Retrieve time check box, you may enable/disable to extend the relay operation time and set the duration in second.
4. Click **OK** to exit and accept the setting and **Cancel** to exit without saving the setting.

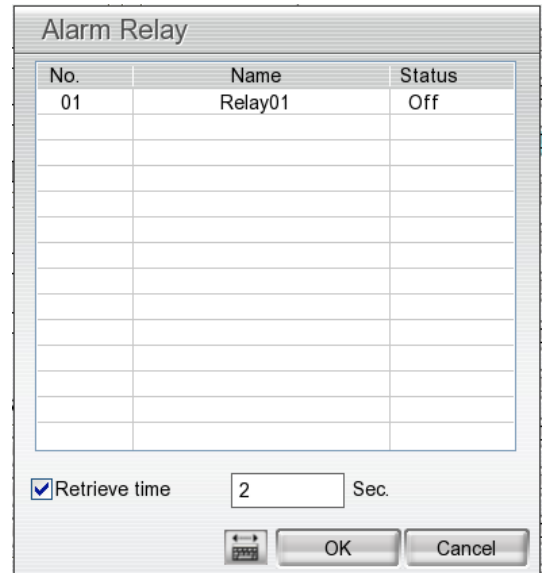

- **Play Warning Sound**

Play alarm sound.

- **Send E-mail**

Send an electronic text message. Beside the Send Email check box, click **Detail**.

In the E-mail Setting dialog box, click **OK** to exit and save the setting and **Cancel** to exit without saving the setting.

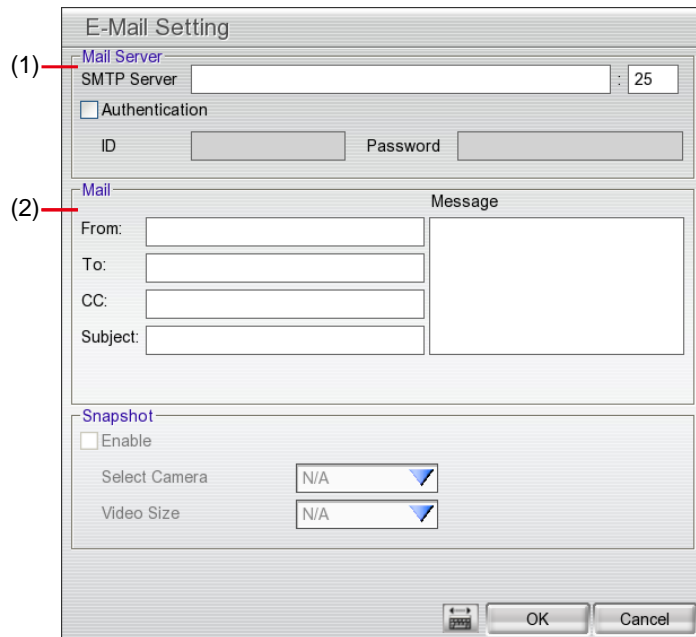

(1) Mail Server

Enter the **SMTP Server** and **port**. If your e-mail system requires user identification, enable **Authentication** check box and enter **ID** and **Password**.

(2) Mail

Fill the mailing information.

From: Enter the sender e-mail address.

To and CC: Enter the recipient email address and separate it with comma or a semicolon (;).

Subject: Enter the message title.

Message: Type the message.

- **Start Recording**

Record the video from the selected camera.

1. Beside the Start Recording check box, click **Detail**.
2. In the Alarm Recording Setting dialog box, select the camera to enable/disable video recording. Enable **All** to select all cameras.
3. In the Frame Rate selection, select **As Setting** to record the number of frames based on the Recording Setting.
4. In the **Start Record prior** text box, mark and set the number in second for the program to begin recording after the alarm has been trigger. The time range is 1~10 seconds.
5. In the **Stop Record after** text box, mark and set the number in second for the program to continue recording after the alarm has ended. The time range is 1~999 seconds. If user doesn't mark and set the time, the alarm recording will continue recording until alarm is reset.
6. Click **OK** to accept the new settings and **Cancel** to exit without saving.



- **Send to CMS (Central Management System)**

Enable/disable the selected camera to send video to CMS when the alarm is activated.

Beside the Send to CMS check box, click **Detail**.

In the CMS Setting, select the camera to enable/disable sending the video to CMS. Enable **All** to select all cameras. Then, click **OK** to accept the new settings and **Cancel** to exit without saving.



using internet explorer.

- **Remote Console**

Allow the user to remote modify DVR system setting.

- **Remote LogViewer**

Allow the user to view the event log from remote site.

- **IP Camera**

Enable/disable user to add new IP camera when using the Web Viewer.

- **Remote Access Time**

Enable **Infinite** check box to access DVR without time limit. If you want to set time limit, enter the number of minutes in **Minute** text box.

(4) Visible Camera

Select the camera number that would allow the user to access or view. To select all the cameras, enable the **ALL** check box.

(5) Time Span

Set the user account a specific time period that user only can use given account to login DVR program in that specific period. Mark **Enable** check box and select the **Activation Date** and **Expiry Date**.

(6) Name

Enter the user name.

Description

Enter the user description.

Password

Enter the user password.

Confirm Password

Enter the same user password for confirmation.

Chapter 4 Using the USB Playback Console

4.1 Recommended system requirements

- Pentium®4 2.4GHZ or above
- Windows®2000/ XP
- DDR 256 MB
- Graphic function must support DirectDraw
- Audio card or built-in
- Speaker
- 1 available USB2.0 port

4.2 Installing the USB Playback Console

To install the USB Playback Console:

1. Place Installation CD into the CD-ROM drive. When the installation main screen appears, click **Install USB Playback Console** and then follow the on screen instructions.



2. Select the language you prefer.









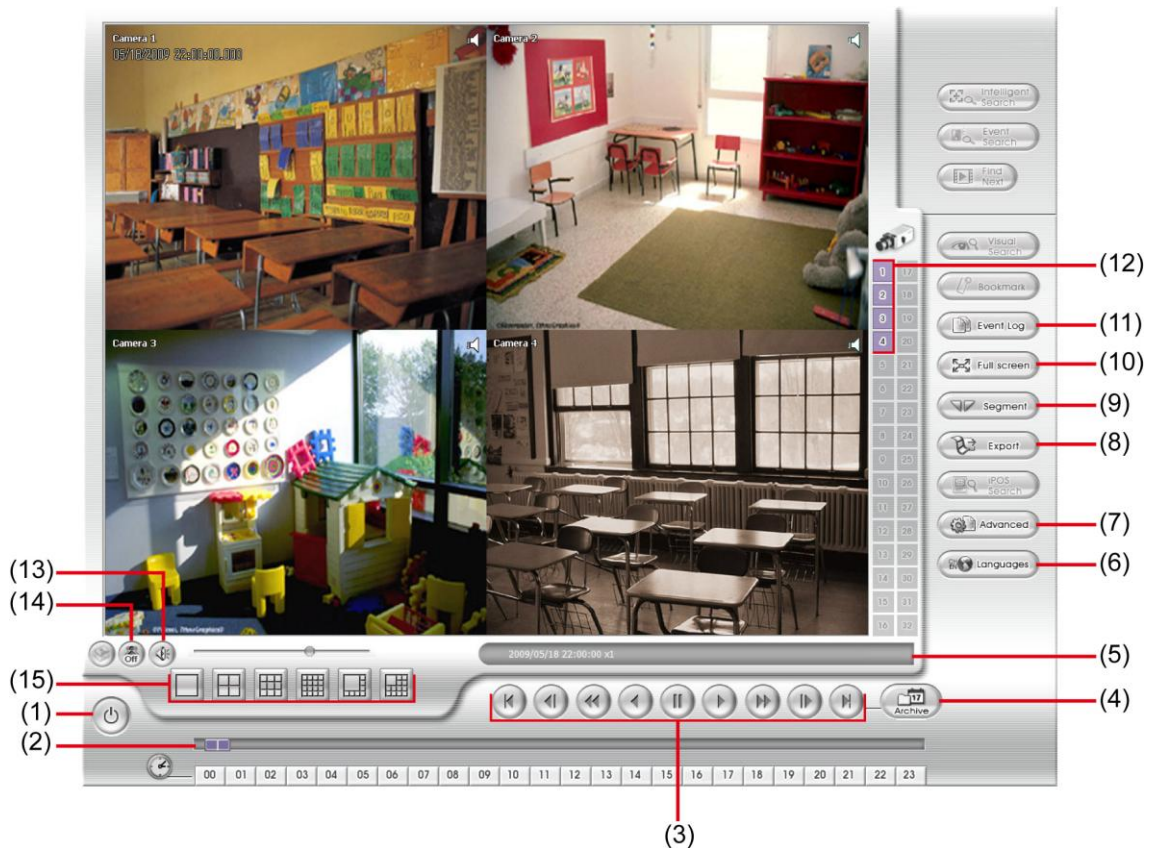

3. Click **OK** to install the application.
4. Click **Exit** to close the installation main screen.
5. You may now connect the DVR unit to PC by using USB cable.

4.3 Running the USB Playback Console

To run the application, click the  icon on the PC desktop



Name	Function
(1) Exit	To close the application.
(2) Progress bar	Show the progress of the file being played. You may move the bar to seek at any location of the track.
(3) Playback Controller	<ul style="list-style-type: none">  Begin: Move at the beginning of the recorded video file.  Previous: Go back to the previous frame by frame.  Slower: Play the recorded video file at the speed of 2x, 4x, or 8x.  Rewind: Wind back the recorded video file.  Pause: Briefly stop playing the recorded video file.  Play: Play the recorded video file.  Faster: Play the recorded video file at the speed of 2x, 4x, 8x, or 16x  Next: Go to the next frame by frame.  End: Go to the end of the recorded video file.

Name	Function
------	----------

(4) Open File To select the video file source for playing.



- **DVR Recorded File (HD):** To playback the recorded video from the hard disk which was recording video on the DVR system. (see also [Chapter 4.3.2](#))
- **Backup File(.dvr):** The file is backup and save in *.dvr file format. (see also [Chapter 4.3.3](#))
- **Backup File (.avf):** The file is backup and save to external USB storage device in *.avf format. Select the file source folder and click **OK** to playback(EXR DVR doesn't support *.avf file format).

(5) Status bar Display the recorded date, time and play speed.

(6) Language To switch language of function tips.

(7) Advanced Advanced function is including :

- **HDD Backup:** to call out HDD Backup application. (see also [Chapter 4.3.4](#))
- **iEnhance:** to call out iEnhance application. (see also Chapter 5)

(8) Export Export includes Snapshot, Print, Output Video Clip, and Export KML function.

- **Snapshot:** Capture and save the screen shot either in *.jpg or *.bmp format.
- **Print:** Print the screen shot.
- **Output to AVI:** Save the segmented file in *.avi format

(9) Segment Keep a portion of the recorded video (see also [Chapter 4.3.1](#))

(10) Full screen Use the entire area of the screen to only display the video. To return, press the right button of the mouse or **ESC** on the keyboard.

When you switch to full screen in multiple-screen mode, Left click to toggle to only display one of the video in the multiple-screen mode or all.

(11) Event List Select the event you want to playback. The event list only available when user select to playback in **DVR Recorded File(HD)**.

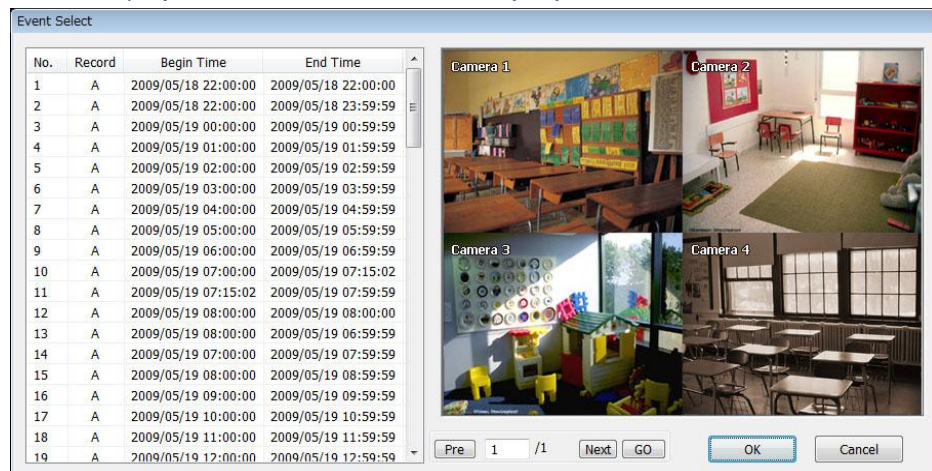

(12) Camera ID Show the number of cameras that are being viewed. When you are in single screen mode, click the camera ID number to switch and view other camera.

(13) Sound /Sound bar Turn on and off the sound
Increase and decrease the volume

(14) De-interlace To enhance the video quality. Set the de-interlace mode to #1, if you are capturing motionless picture and #2, if it captures lots of movement.

Name	Function
(15) Split Screen Mode	Select from different screen view to playback the recorded video file of the entire camera or one camera on screen.

4.3.1 To Cut and Save the Portion of the Recorded Video

1. Use the Playback Control buttons or drag the bar on the playback progress bar and pause on where you want to start the cut. Then, click **Segment** to set the begin mark.



2. Use the Playback Control buttons or drag the bar on the playback progress bar and pause on where you want to end the cut. Then, click **Segment** to set the end mark. To cancel segmentation, click **Segment** button again.



3. Click **Export > Output Video Clip** button to save the wanted portion.
4. In the **Save As** dialog box, locate on where user wants to save the file, type the filename, and select the video format.

4.3.2 Playback DVR Recorded File from Hard Disk

1. Please have the hard disk which containing of recorded video data install on your PC or using external USB enclosure to connect to your PC.
2. Click **Open File** button
3. Select **DVR Recorded File(HD)** and click **OK**.
4. Select the hard disk drive from **Select Disk** window and click **OK**.

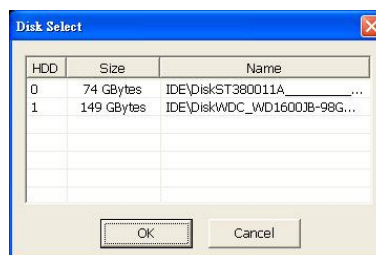

5. And then, Playback Date/Time Selection window appears. Select the date and time and click **OK**.

4.3.3 Playback Backup File(*.dvr)

1. Click Open File button.
2. Select **Backup File(*.dvr)** and click **OK**.
3. Locate the backup file folder and click **OK**.

 When open the backup video file, just located the folder of backup file

4. And then, Playback Date/Time Selection window appears. Select the date and time and click **OK**.

 When channels of the DVR is less than 16 channels, the **Channel 01~~16** and **Channel 17~32** buttons are nonfunctional.

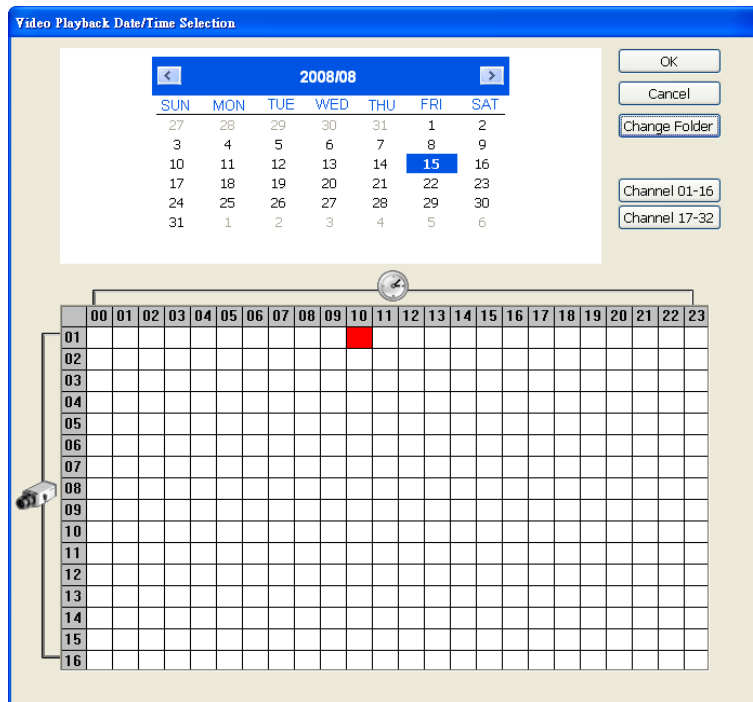

4.3.4 To Backup Recorded File

HDD backup function allows user to backup recorded file from hard disk.

1. Click **Adv. Function** → **HDD Backup** on USB Playback Console UI.
2. Select the source hard disk.

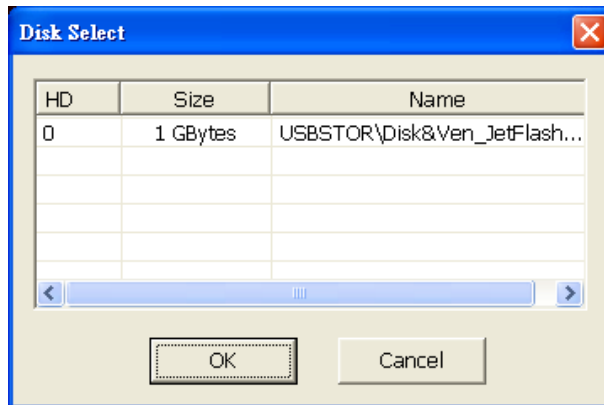

3. In Backup date/time selection window, select the date and time. 00-24 represents hours and 01-04 represents channels. Blue block means there has recorded file. Red block means the block has been selected. Click-and-drag can select multiple block at once.

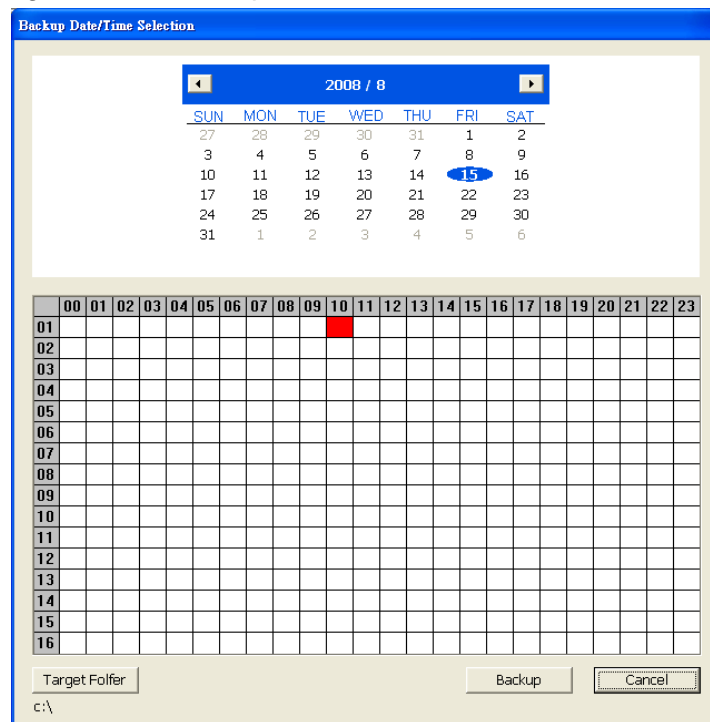

4. Click **Backup** to start backup file.
5. When backup complete, the complete information window will display.

Chapter 5 iEnhance

The bundled iEnhance is a video editing tool and can only be used with *.dvr video file. It allows you to adjust the video picture quality, segment and save the selected portion of the video, zoom in and out the image, and print or save the screen shot. You can also save the setting and apply it on other files.

To run iEnhance application, click **iEnhance** button on USB Playback Console interface.

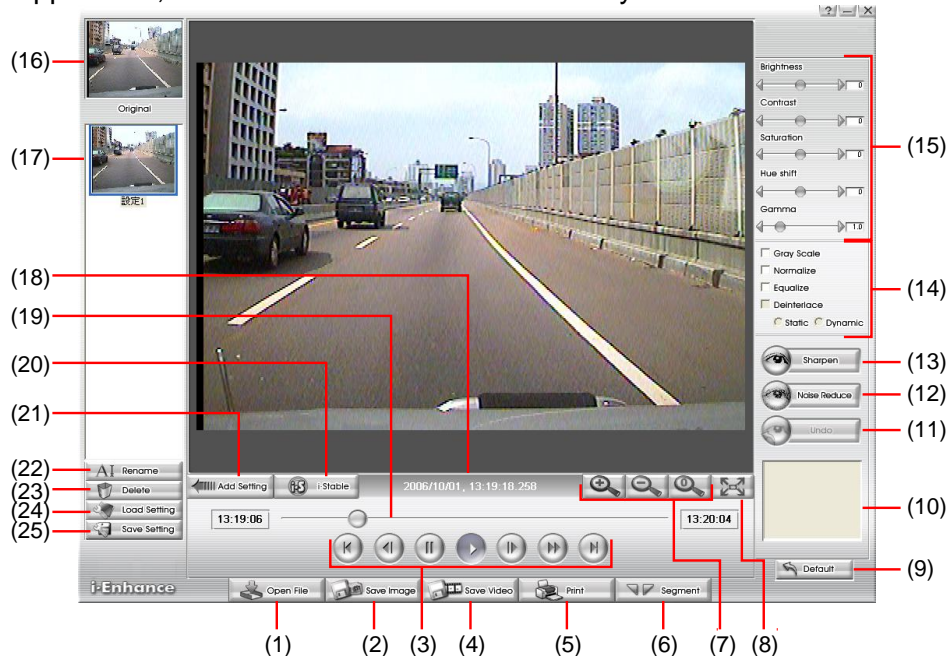

Name	Function
(1) Open File	Access *.dvr video file.
(2) Save Image	Capture and save the screen shot in *.bmp format.
(3) Playback Control Buttons	<p>Begin: Move at the beginning of the video file.</p> <p>Previous: Go back to previous frame.</p> <p>Pause: Briefly stop playing the video file.</p> <p>Play: Play the video file.</p> <p>Faster: Play the video file at the faster speed.</p> <p>Next: Go to the next frame.</p> <p>End: Go to the end of the video file.</p>
(4) Save Video	Save the edited or segmented video in *.avi format.
(5) Print	Print the screen shot.
(6) Segment	Mark the beginning and the end of the selected portion of the video. Two triangle marks will appear on the slider. To cancel video segmentation, click this button again.
(7) Zoom Buttons	Enlarge, reduce, and set the image back to normal size.
(8) Full Screen	Use the entire screen to only display the video.
(9) Default	Set the video back to original state and delete all the changes in the history box.
(10) History Box	List all the actions.
(11) Undo	Delete the last action.
(12) Noise Reduce	Adjust the softness and repair the damaged colours.

Name	Function
(13) Sharpness	Improve the overall image by enhancing edges. This gives the image more depth.
(14) Effects	<p>Gray Scale: convert the image into black and white (monochrome).</p> <p>Normalize: adjust the brightness intensity.</p> <p>Equalize: automatically adjust the images that are too dark.</p> <p>De-interlace: smooth out the overlying frames.</p> <ul style="list-style-type: none"> ■ Static: de-interlace for motionless scene. ■ Dynamic: de-interlace for moving scene.
(15) Picture Adjustment	Adjust the Brightness, Contrast, Saturation, Hue and Gamma.
(16) Original Screen	Display the original state of the image.
(17) Temporary Setting Block	Display the sample settings. Click the sample to apply the setting on the current video.
(18) Status Bar	Display the date, and time of the video.
(19) Progress Bar	Show the progress of the file being played. You may move the bar to seek at any location of the track.
(20) iStable	To reduce the jolt in the recorded video.(also see Chapter 5.1)
(21) Add Setting	Include the new setting to the temporary setting block.
(22) Rename	Change the name of the selected setting in the temporary setting block.
(23) Delete	Permanently remove the selected setting in the temporary setting block.
(24) Load Setting	Call the saved settings.
(25) Save Setting	Store the settings in the temporary setting block.

5.1 To Use iStable

The iStable function can reduce the jolt in the recorded video.

1. Click **Open File** button and select the recorded video.
2. And then, click **iStable** button.
3. iStable window will show up.
4. Select the **smoothness** level – 1(Low), 2, 3, 4, and 5(High). The default value is 3.
5. Click Play button, and then iStable function will start to initial the recorded video.
6. When the initialize is done, user will see the original and stabilized recorded video play in two window.

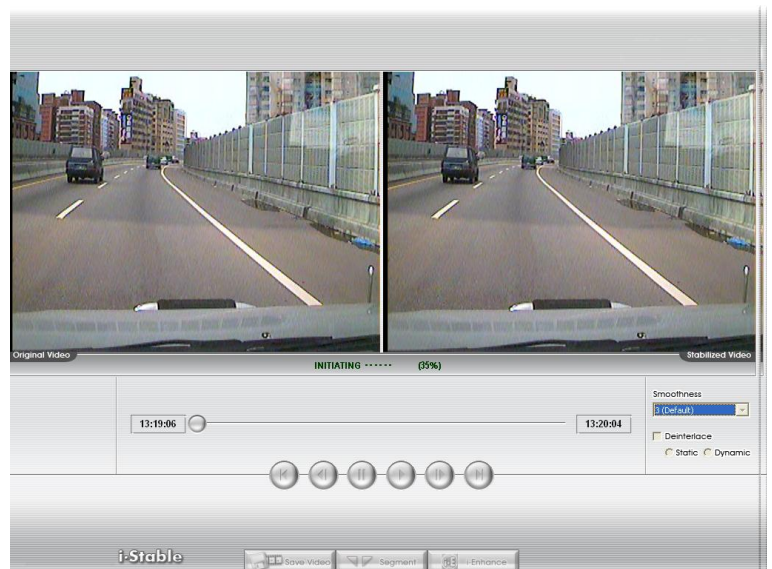

Chapter 6 Using the Remote Programs

User can use Microsoft Internet Explorer to access DVR system by entering the IP address. To use this feature, make sure that your PC and DVR server both are connected to the internet and the Network feature is enabled.

Accessing this feature for the first time you will be prompted by your browser to install **WebCamX.cab**, allow the installation and you should be able to connect and login afterwards. Click Install when the Internet Explorer - Security Warning dialog box appears.

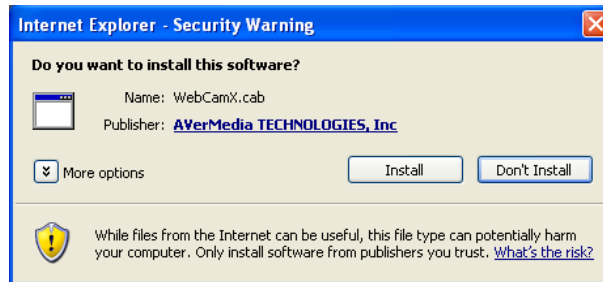

After installing the WebCamX.cab and when connecting to the DVR system, you are required to enter account ID (default is **superuser**; case sensitvie) and password (default is **11111**) and select the type of network. **Superuser** has the authority to remote setup the DVR system configuration on WebViewer. **User** only can preview the video on WebViewer and Remote Console.

i Changing account password is strongly recommended.

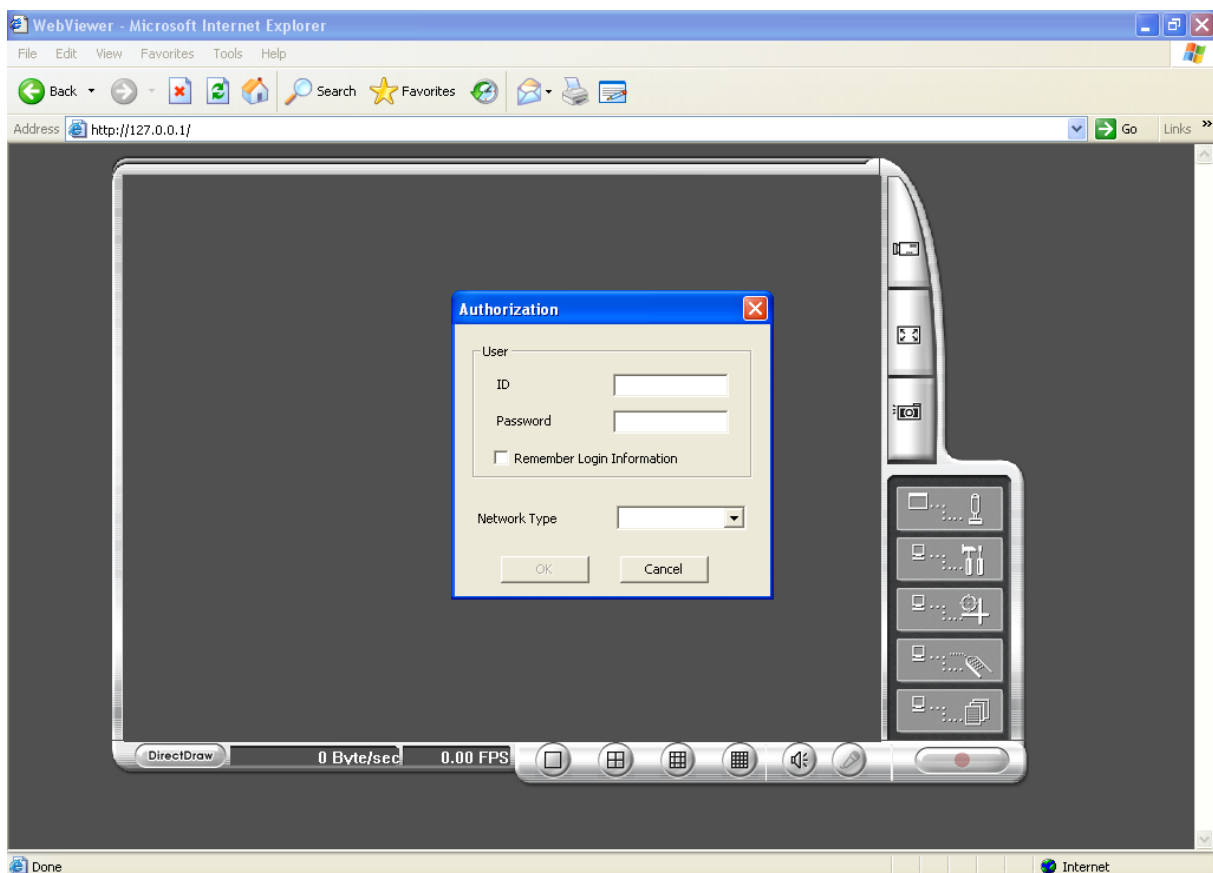

6.1 Familiarizing the Buttons in WebViewer

Right-clicking on the WebViewer video screen, enables you to start video recording, change video quality, switch camera and enable/disable DirectDraw.



Name	Function
(1) DirectDraw	Enhance the video quality.
i	Not all graphic cards can support this function. If you cannot see the screen display correctly or screen is messed, please check with VGA card vendor.
(2) Received file size	Indicate the size of the data being sent per second.
(3) Camera frames	Indicate the number of frames per second.
(4) One screen view	To view single camera view on screen. User can right click on the screen to switch to different camera view.
(5) Split screen view	To view all cameras on screen simultaneously.
(6) Audio	Enable/disable remote sound.
(7) Record	Start to record the video of the selected camera in AVI format. Directly click screen to select the channel that user wants to record and press Record button.
(8) Remote Console	Initiate Remote Console. It allows you to control DVR server (see also Chapter 6.2).
(9) Event Log Viewer	Display the Event logs, Operation logs, System logs, and Network logs.
(10) Remote setup	Change the DVR server settings (see also Chapter 6.1.1)
(11) PTZ Control	Initiate PTZ camera controller.
i	The EXR6004 WiFi doesn't support PTZ function.
(12) Snapshot	Capture and save the screen shot in *.bmp format.
(13) Full screen	Use the entire area of the screen to only display the video. To return, Right click the mouse or press ESC on the keyboard.

Name	Function
(14) Select cameras to view	<p>Select to the view camera from different server. In Select Camera dialog box, Display column, click to enable/disable viewing the camera.</p> <p>Click Add Server and select the server type between DVR and IP Cam to add.</p> <p>Click Delete Server to delete the selected item.</p> <p>Click Import to load the previous saved list.</p> <p>Click Export to save the list.</p> <p>Click Apply All to change all the camera video quality based on the selected setting.</p> <p>Click OK to exit.</p>

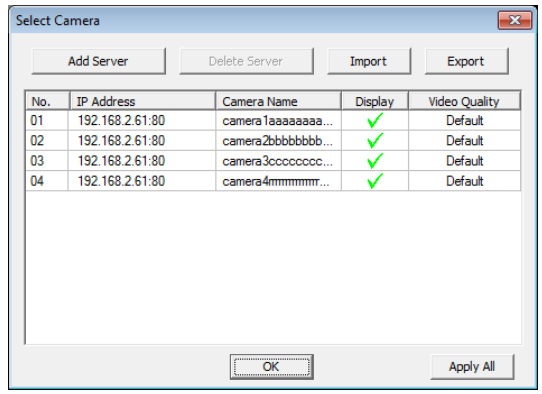

6.1.1 To Setup Remote System Setting

The setting here applies to Remote DVR only.

6.1.1.1 System Setting

In the System Setting window, click **Update** to accept the new settings, click **Exit** to exit without saving, and click **Default** to revert back to original factory setting.

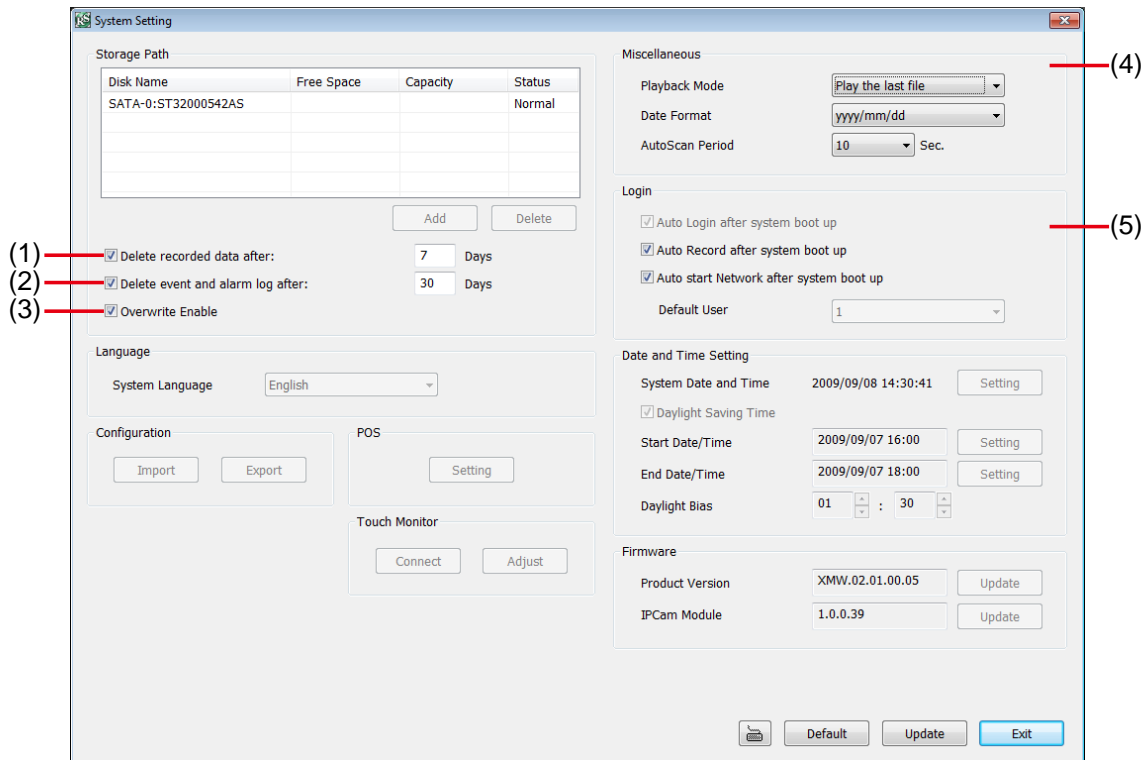

(1) Delete recorded data after

If you want the system to automatically erase the data after a certain days, enable the **Delete recorded data after** check box and enter the numbers of days in **Days** text box.

(2) Delete event and alarm log after

If you want the system to automatically erase the event and alarm log files after a certain days, enable the **Delete event and alarm log after** check box and enter the numbers of days in **Days** text box.

(3) Overwrite Enable

When there is not enough free space to record one hour data, the system automatically replaces the oldest data.

(4) Miscellaneous

Enable the conditions in **Miscellaneous** section you want the system to perform.

- Playback Mode

Select the mode of playback the video.

- ✓ **Select date and time:** Select the date and time which user wants to playback.
- ✓ **Play the last file:** Automatically playback the video from the last hour
- ✓ **Instant Playback:** Automatically playback the video which has just recorded

- Date Format

Select the date format which wants to display in **Select date and time** playback mode

- Auto Scan Period

Set the time gap of the Auto Scan function from 3 to 10 seconds. This automatically switches to the next video in cycle depending on the set time gap.

(5) Login

Enable the conditions in Login section you want the system to automatically carry out.

- **Auto Record after system boot up**

Automatically start video recording when the DVR is executed.

- **Auto start Network after system boot up**

Automatically connect to network when the DVR is executed.

6.1.1.2 Camera Setting

Select the camera from remote DVR servers to modify settings. In the Camera Setting window, click **Update** to save and apply the new settings, click **Exit** to exit without saving.

IP Camera Setting

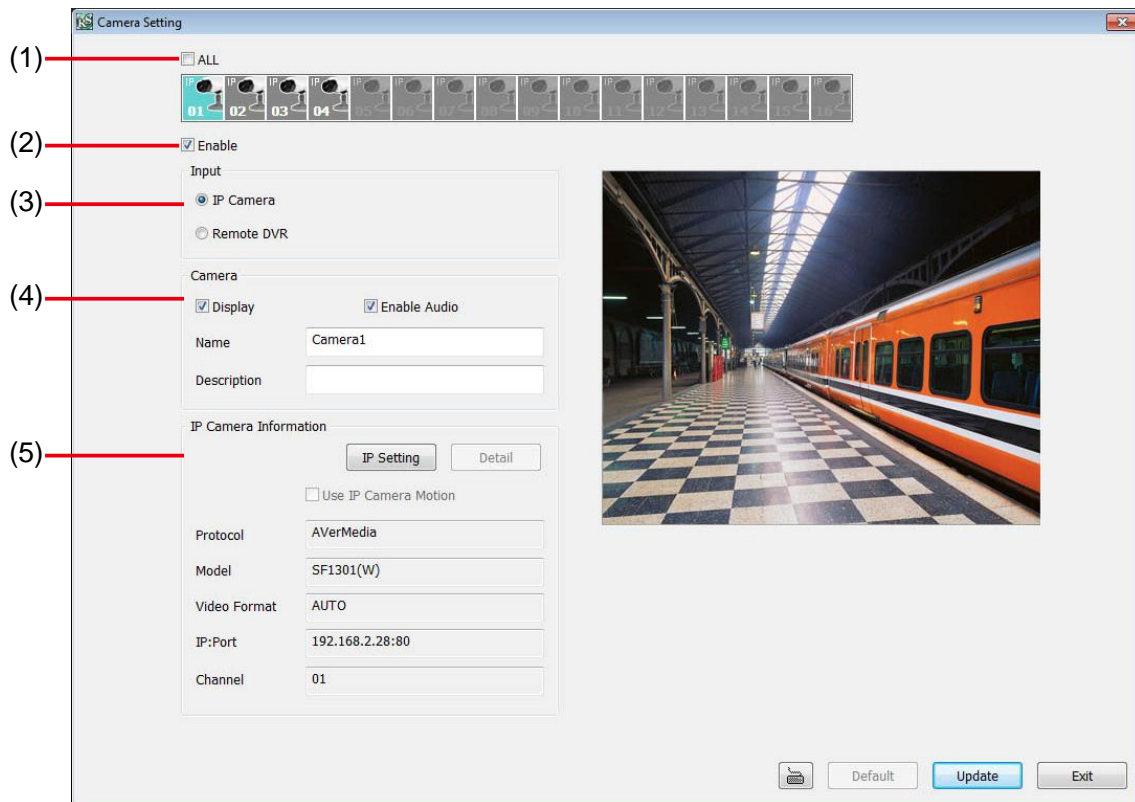

(1) Camera Icons

Select the camera number you want to adjust the video setting. To select all the cameras, enable the **ALL** check box. To select more than one camera, Right click on the camera icon. To select one camera only, Left click on the camera icon. The camera icon turns red when it is selected.

(2) Enable

Set to enable/disable the selected camera. When there is no video source on the camera, we suggest disabling it so that the system won't detect it as video loss error.

(3) Input

Select the type of camera as IP camera. To modify camera of remote DVR, see [Remote DVR Camera Setting](#).

(4) Camera

- **Display**

Enable/disable to show the video. Even if the video of the selected camera is hidden you can still record the video and preview it in playback mode.

- **Enable Audio**

Enable/disable audio of the camera.

- **Name**

Change the camera name

- **Description**

Add a short comment

(5) IP Camera Information

Click **IP setting** to view IP camera's detail information. User can view current connected wireless IP camera information such as **Protocol**, **Model**, **Video Format**, **Channel**, and **IP Camera Site**(IP address of IP camera). If wireless IP camera has enabled the authentication, user can mark **Authentication** check box and enter the **ID** and **password** of the IP camera. The **URL** is not supported in here.

To exit the IP Camera Settings windows, click **OK** to save the changes and exit. Click **Exit** will not save any changes and exit.

The screenshot shows a window titled "IP Camera Settings" with a close button in the top right corner. The window is divided into several sections:

- IP Camera Information**: This section contains a "Protocol" radio button (selected) next to a dropdown menu showing "AVerMedia" and a "Search Devices" button. Below this are dropdown menus for "Model" (SF1301(W)), "Video Format" (AUTO), and "Channel" (1).
- IP Camera Site**: A text input field containing "192.168.2.28" followed by a colon and a port input field containing "80".
- URL**: A radio button (unselected) next to a text input field containing "http://".
- Authentication**: A checked checkbox next to the label "Authentication". Below it are text input fields for "ID" (containing "admin") and "Password".

At the bottom right of the window are two buttons: "OK" and "Cancel".

Remote DVR Camera Setting

Select the camera to modify settings. In the Camera Setting window, click **Update** to save and apply the new settings, click **Exit** to exit without saving.

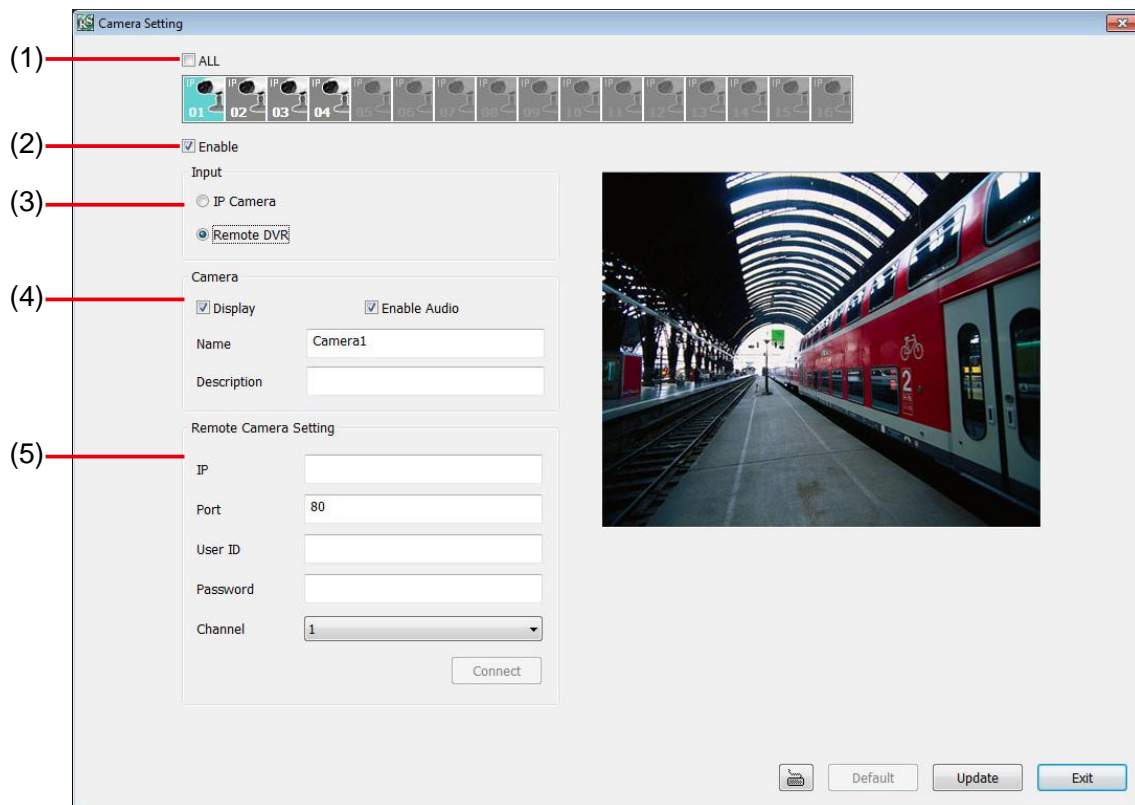

(1) Camera Icons

Select the camera number you want to view. To enable/disable all cameras, click **ALL** check box.

(2) Enable

Set to enable/disable the selected camera. When there is no video source on the camera, we suggest disabling it so that the system won't detect it as video loss error.

(3) Input

Select the camera type as **Remote DVR**. For IP camera setting, see [IP Camera Setting](#).

(4) Camera

- **Display**
Enable/disable to show the video. Even if the video of the selected camera is hidden you can still record the video and preview it in playback mode.
- **Enable Audio**
Enable/disable audio of the camera.
- **Name**
Change the camera name
- **Description**
Add a short comment
- **IP**
Enter the IP address of the camera
- **Port**
The port for connection
- **User ID**
Enter the user id that for connecting authority
- **Password**
Enter the password that is for connecting authority
- **Channel**
Select the channel of connected camera

6.1.1.3 Record Setting

In the Recording setup window, click **OK** to accept the new settings, click **Exit** to exit without saving, and click **Default** to revert back to original factory setting.

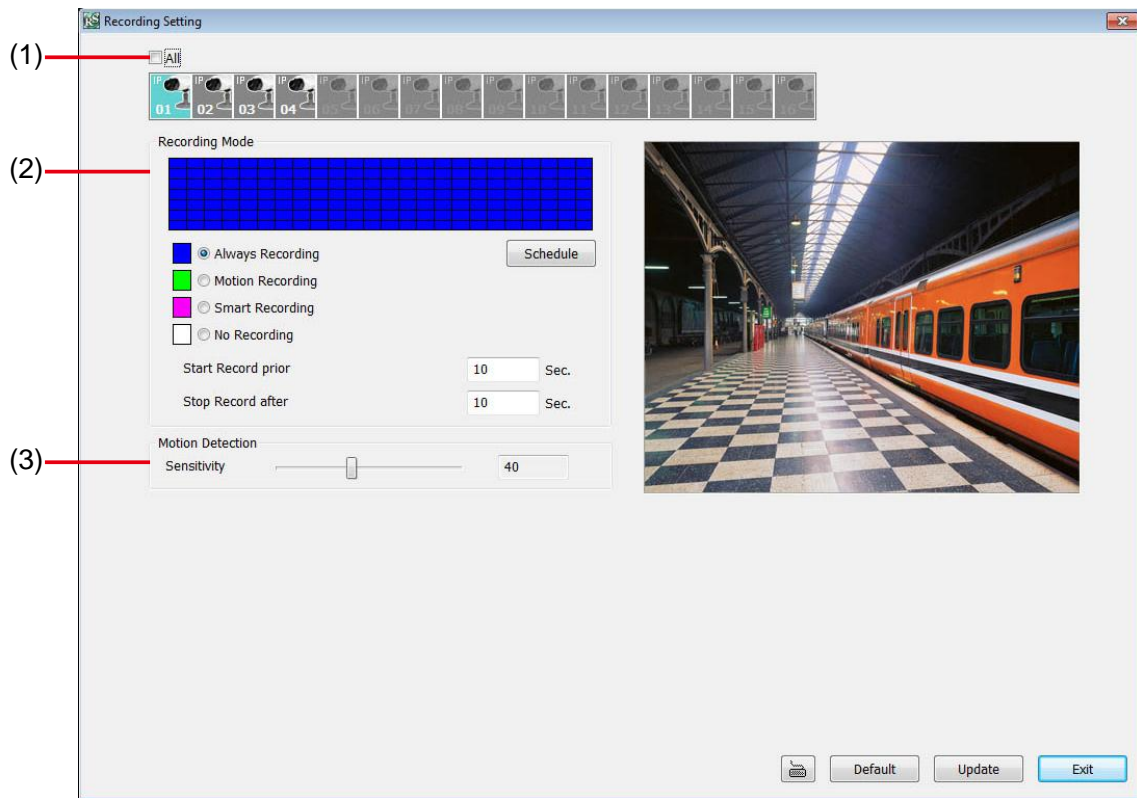

(1) Camera Icons

Select the camera number you want to set the recording setting. To select all the cameras, enable the **ALL** check box. To select more than one camera, **Right click** on the camera icon. To select one camera only, **Left click** on the camera icon. The camera icon turns purple when it is selected.

(2) Recording Mode

The horizontal blocks from 00 to 23 represent the time in 24-hour clock and the vertical block 1 to 7 represent the day in the week block (Sunday to Saturday). To record in full 24 hours and 7 days a week, select the recording mode and click the **☉** button. If you want to only record at a particular time or day, click **Schedule** button and select the **Recording Mode**, and then click on the time or day blocks. When the system starts recording a red triangle mark would appear at the upper left corner of the screen.

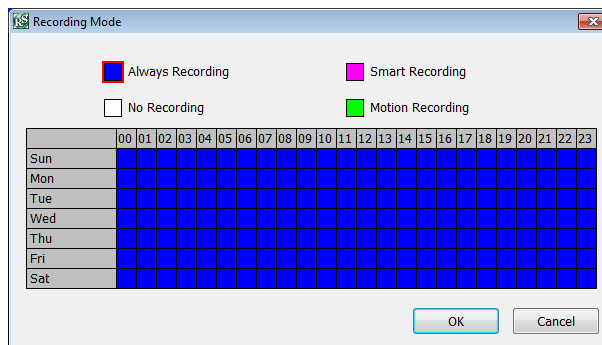

The recording modes are listed below:

- **Always Recording**
Record the video from the selected camera and save it to the designated storage path
- **Motion Recording**
Start recording the video from the selected camera only when the system detects movement. Once a motion is detected, the system automatically saves the previous frames and stop based on the **Start Record Prior** and **Stop Record After** settings.

- **Smart Recording**

Automatically switch to recorded at the maximum frame rate setting once a motion is detected and if there is no motion, it records at the minimum frame rate setting.

- **No Recording**

The system won't do any recording.

(3) Motion Detection

Adjust the sensitivity of the motion detection. The higher the value, the finer the sensitivity is detected. When it detects a motion, a green triangle mark would appear at the upper left corner of the screen.

6.1.1.4 Network Setting

In the Network Setting dialog box, click **Update** to accept the new settings, click **Exit** to exit without saving, and click **Default** to revert back to original factory setting. For the network service ports that use by DVR server, please see [Appendix A](#).

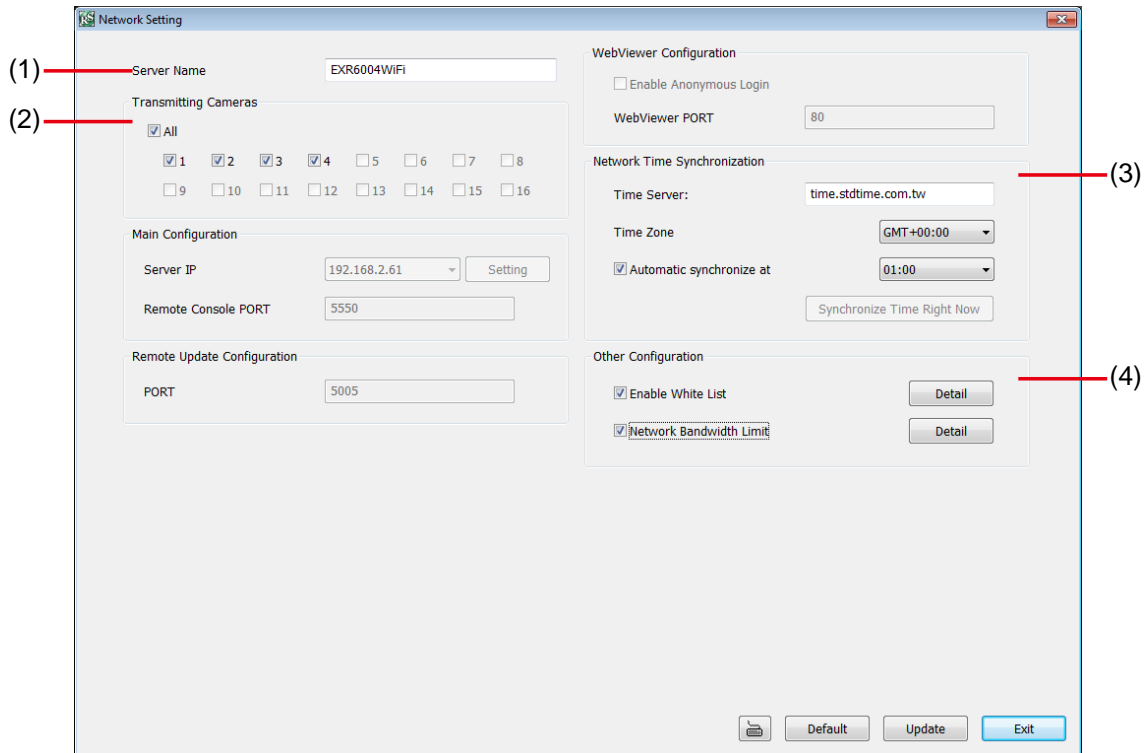

(1) Server Name

Assign a name for the DVR unit. Alphabet letters and numbers only.

(2) Transmitting Cameras

Select and click on the camera number in the Transmitting Camera section you want to make it accessible via internet using WebViewer, Remote Console, PDA Viewer and JAVAVIEWER (still image). To select all the cameras, enable the **ALL** check box.

(3) Network Time Synchronization

Adjust the DVR system time same as network time server. Fill in the **Time Server** IP address or domain name. Select the **Time Zone** that DVR is located. And then, mark the **Automatic Synchronize** time to set automatic synchronize time on a daily basis.

(4) Other Configuration

- Enable White List

An access permit list for the remote accessing of DVR server. Enter the IP address and click **Add**. Or, enter a range of IP address and click **Add**. To delete the IP from the list, select the IP and click **Delete** button. To reset the input, click **Clear** button.

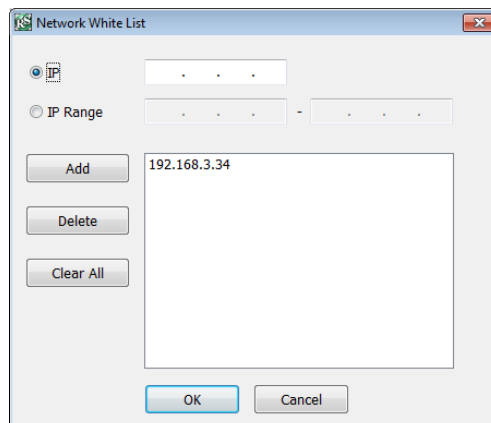

- **Network Bandwidth Limit**

By Channel: Set the network bandwidth by each channel.

All: Set the total network bandwidth consumption limit.

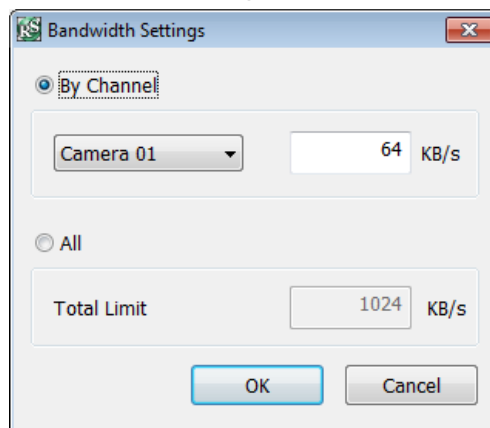

6.1.1.5 Alarm Setting

In the Alarm Setting dialog box, click **Add** to insert and set new alarm setting, click **Delete** to remove the selected alarm setting, click **Update** to save the setting, **Exit** to exit without saving, and **Default** to revert back to original factory setting.

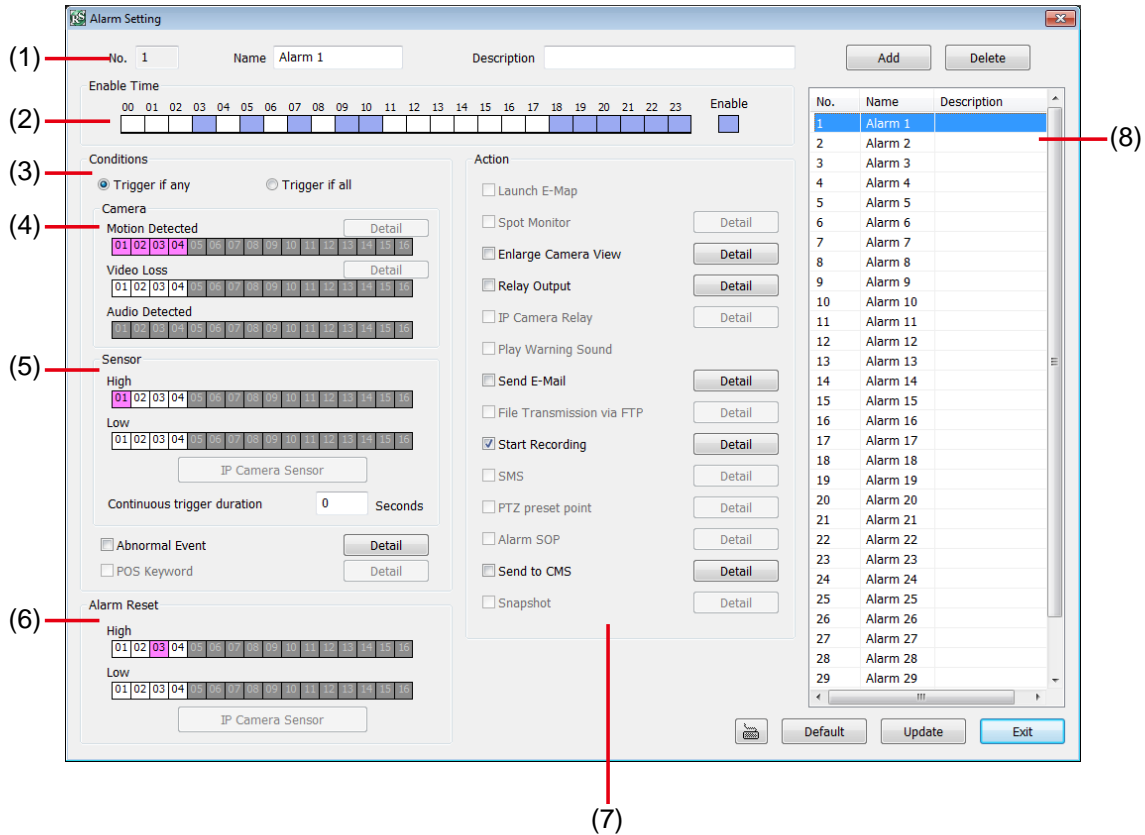

1. Click **Add** to insert and set a new alarm setting. Click the items in the **(8) Alarm Setting List** if you want to modify the alarm setting.
2. In **(1) No./Name/Description** enter alarm name and description. Alarm **No.** will be created by DVR system.
3. In **(2) Enable Time**, the number from 00 to 23 represent the time in 24-hour clock. Select the time and click the block you want to activate or deactivate the alarm function. When it is deactivated the color of the block turns white.
4. In **(3) Conditions**, you can set “**Trigger if any**” to activate if it falls to one of the conditions or “**Trigger if all**” to activate if it falls to all conditions.
5. In **(4) Camera** section, select and click on the camera number (01 to 04) in **Motion Detected** and **Video Loss** to set the condition for the system to alarm.
6. In **(5) Sensor**, select and click on the sensor number to set the condition for the system to alarm. If the sensor normal status is high, set the sensor condition to low.
 - Enable/disable the **Abnormal Event** check box, to set the condition of the event for system to alarm.

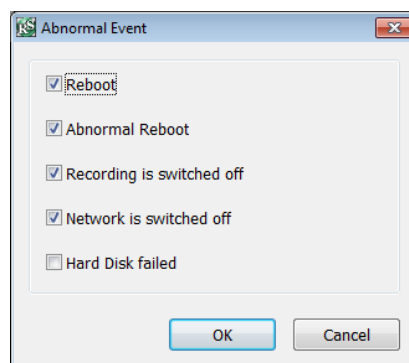

- **Reboot:** when the DVR system reboot without abnormal condition, the system will send out the alarm message.
 - **Abnormal Reboot:** when the DVR system reboot in irregular condition, the system will send out the alarm message.
 - **Recording is switched off:** when the recording has been stopped, the system will send out the alarm message.
 - **Network is switched off:** when the network connection of DVR system is lost, the system will send out the alarm message.
 - **Hard Disk failed:** when the hard disk doesn't work normally, the system will send out the alarm message.
- **Continue trigger duration:** Set a time period that when sensor has been trigger and stay in the same status for that period, then the alarm will be sent out.
7. In **(6) Alarm Reset**, click the camera number to set the reset condition of alarm. Once alarm is reset, all alarm action will stop at the moment. If the sensor normal status is high, set the alarm reset condition to low.
8. In **(7) Action**, you may now set the alarm action for the system to perform when the alarm condition is activated.
- **Enlarge Camera View**
- Switch to only display video in Preview mode from where the alarm is activated.
- a. Select the camera from drop down list to specify which camera video to be enlarged on screen when the alarm is triggered.
 - b. **Retrieve time:** set the waiting duration before system switching back to original Preview mode. If the retrieve time is un-mark, the alarm video will keep enlarging until user switch back to Preview mode manually. The retrieve time range is 0~ 600 seconds.

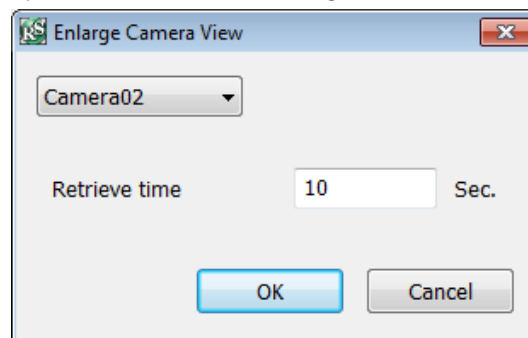

- **Relay Output**

Set to enable/disable the relay operation when the alarm is activated and to extend additional time in second before it stops the relay operation.

1. Beside the Relay Output check box, click **Detail**.
2. In the Alarm Relay dialog box, select from the available relay list and in the ON column, set to enable/disable the relay operation when the alarm is activated.
3. In the Retrieve time check box, you may enable/disable to extend the relay operation time and set the duration in second.
4. Click **OK** to exit and accept the setting and **Cancel** to exit without saving the setting.

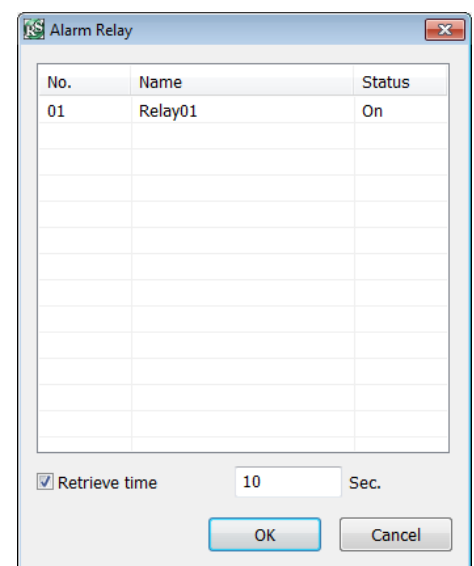

- **Send E-mail**

Send an electronic text message. Beside the Send Email check box, click **Detail**.

In the E-mail Setting dialog box, click **OK** to exit and save the setting and **Cancel** to exit without saving the setting.

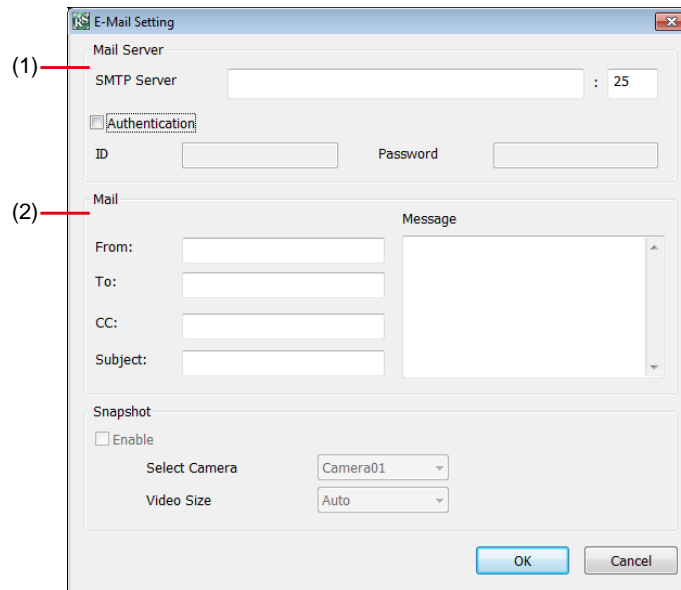

(1) Mail Server

Enter the **SMTP Server** and **port**. If your e-mail system requires user identification, enable **Authentication** check box and enter **ID** and **Password**.

(2) Mail

Fill the mailing information.

From: Enter the sender e-mail address.

To and CC: Enter the recipient email address and separate it with comma or a semicolon (;).

Subject: Enter the message title.

Message: Type the message.

- **Start Recording**

Record the video from the selected camera.

1. Beside the Start Recording check box, click **Detail**.

2. In the Alarm Recording Setting dialog box, select the camera to enable/disable video recording. Enable **All** to select all cameras.

3. In the Frame Rate selection, select **As Setting** to record the number of frames based on the Recording Setting.

4. In the **Start Record prior** text box, mark and set the number in second for the program to begin recording after the alarm has been trigger. The time range is 1~10 seconds.

5. In the **Stop Record after** text box, mark and set the number in second for the program to continue recording after the alarm has ended. The time range is 1~999 seconds. If user doesn't mark and set the time, the alarm recording will continue recording until alarm is reset.

6. Click **OK** to accept the new settings and **Cancel** to exit without saving.

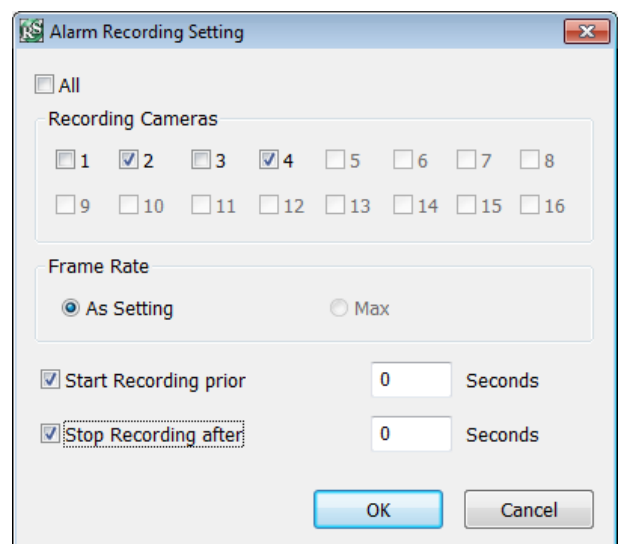

- **Send to CMS (Central Management System)**

Enable/disable the selected camera to send video to CMS when the alarm is activated. Beside the Send to CMS check box, click **Detail**. In the CMS Setting, select the camera to enable/disable sending the video to CMS. Enable **All** to select all cameras. Then, click **OK** to accept the new settings and **Cancel** to exit without saving.

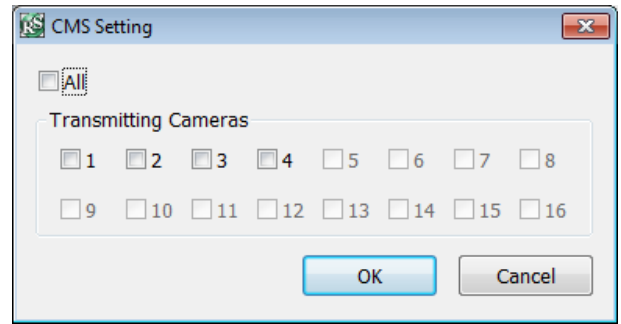

6.2 Familiarizing the Buttons in Remote Console



Name	Function
(1) Exit	Close the Remote Console.
(2) Split Screen Mode	Select from 3 different split screen type to playback the recorded video file of one camera, all the cameras or one camera over the other or alongside on a single screen.
(3) Record	Start/stop video recording.
(4) Network	Enable/disable remote system access. This feature allows you to access DVR server from a remote location via internet connection.
(5) Setup	Configure the Remote Console setting. (see also Chapter 6.2.1)
(6) PTZ	Access PTZ control panel.
<p>i The EXR6004 WiFi doesn't support PTZ function.</p>	
(7) Preview	Switch to Preview/Playback mode. This allows you to view live camera display.
(8) Playback	Switch to Playback mode. This allows you to view the recorded video file. (see also Chapter 6.3)
(9) Status Bar	Display the current date, time and hard disk free space.
(10) Camera ID	Show the number of cameras that are being viewed. When you are in single screen mode, click the camera ID number to switch and view other camera.
(11) Event Log	Display the Event logs, Operation logs, System logs, and Network logs.
(12) Snapshot	Capture and save the screen shot either in *.jpg or *.bmp format.
(13) Auto Scan	Start/stop video screen cycle switch.
(14) Full screen	Use the entire area of the screen to only display the video. To return, Right click the mouse or press ESC on the keyboard.
(15) Alarm	Alert and display warning info. Superuser and user both can reset the alarm.
(16) Audio button	Enable/disable the sound.
(17) DirectDraw	Enhance the video quality.

i Direct Draw function supports for certain VGA card. For more information, please contact your VGA card vendor.

6.2.1 To Setup Remote Console Setting

Click **Setup** button to call out the **System Setting** window. Click **OK** to exit and save the setting and **Cancel** to exit without saving the setting.

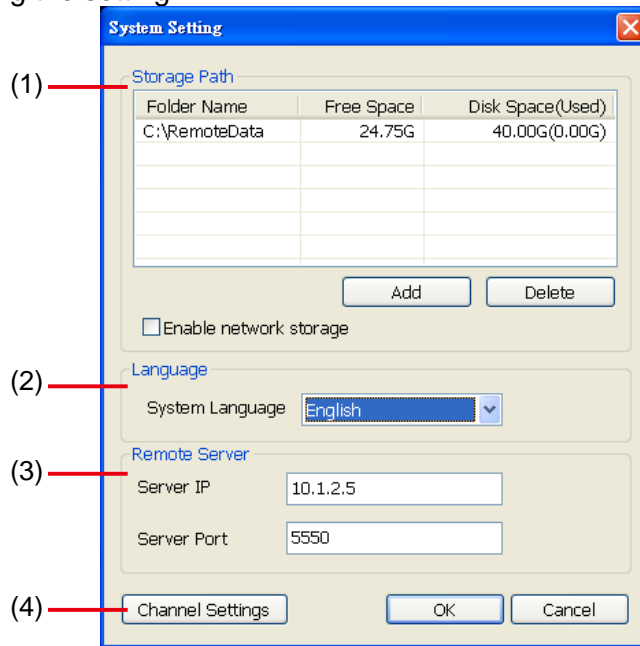

(1) Storage Path

Set the directory on where to save the data. When there is not enough free space to record one hour data, the system automatically replaces the oldest data. In case you have more than one storage path, the system automatically saves the data to the next storage path. By default the data is stored in C:\RemoteData, to insert another storage path, click **Add**. To remove the selected path, click **Delete**.

- **Enable network storage**

Select the Enable network storage check box to send the recorded video in network-attached storage.

i To add network storage, the Internet storage drive/folder must be mapped as Network Driver in DVR server. To know how to assign or connect to a network drive, please refer to your Windows help file and search "Map Network drive".

(2) Language

Customize the system to display the tool tips and dialogs based on the selected language. By default the language is in English.

(3) Remote Server

Enter the DVR Server IP and Server Port number.

(4) Channel Settings

The numbers from 1 to 4 represent the camera ID. In Transmitting Channels section, enable the camera number to receive the camera signal from the server. In Visible Channels section, enable the camera number to view the camera signal on Remote Console screen. To select all the cameras, enable the **ALL** check box.

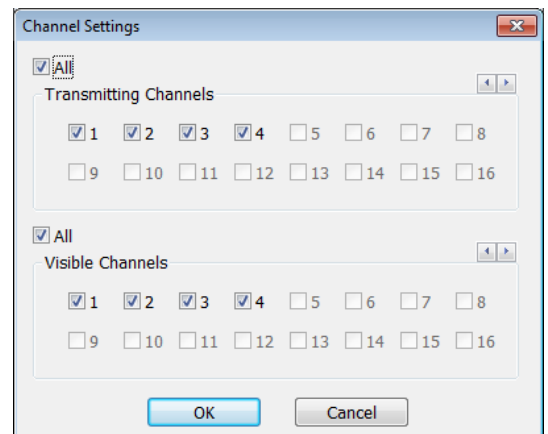

6.3 Using the Remote Playback

To use this feature, first you need to select the source of the file. In the Select Playback Mode dialog box, choose **Local Playback** to open the file that is recorded in the Remote Console, and **Remote Playback** to open the file that is recorded in the DVR server. When you choose Remote Playback, select **RealTime Playback** if your internet bandwidth is fast and big enough, otherwise choose **Download and Playback**.



Click **OK** to proceed and **Cancel** to void this operation.



In the Video Playback Date/Time Selection, the number from 00 to 23 represent the time in 24-hour clock. The numbers from 01 to 04 represent the camera number.

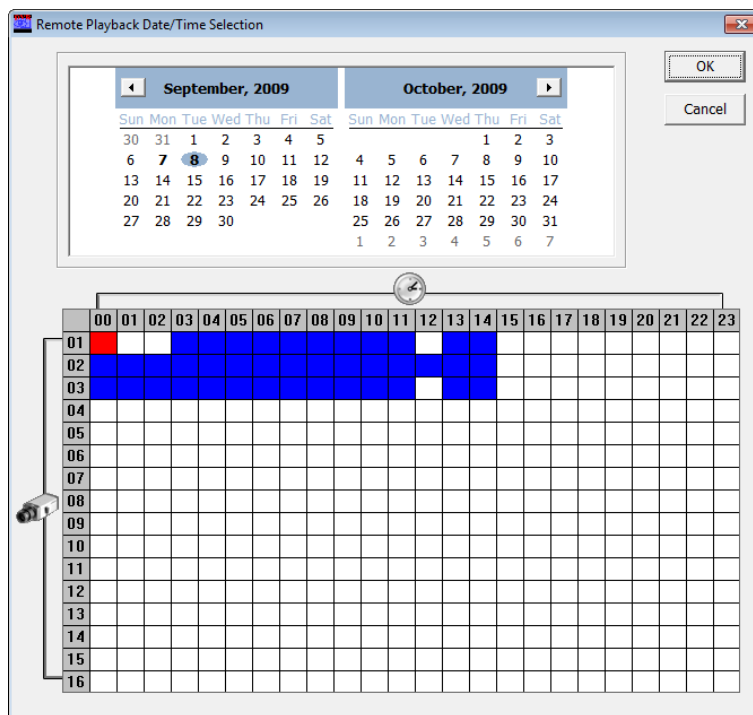

To Make a Selection:

1. Select the date in the calendar. Use ◀ and ▶ buttons to shift the calendar to the left or right.
2. In the table below, click on the blue block to select and open the recorded file. The blue block turns red when it is selected. The block that appears in white doesn't have data. You can only select one block when you choose Download and Playback.
3. Click **OK** to proceed and **Cancel** to void this operation.
4. If you select Download Playback and after making the selection, the system divides the selected hour into 16 video thumbnails. In the Time Selection screen, click on the video thumbnail you want to download (see also [Chapter 6.3.3](#)).



6.3.1 Familiarizing the Buttons in Local Playback



Name	Function
------	----------

(1) Split Screen Mode Select from 6 different split screen type to playback the recorded video file of all the camera, or one camera over the other or alongside on a single screen.



- If there are only 4 cameras, you won't be able to switch to 8, 16, and 13 split screen mode.
- To zoom in an area on the screen, Right click and Drag a square on the area you want to enlarge. To back to normal view, right click the channel screen again.

(2) Exit To close the application

(3) Progress bar Show the progress of the file being played. You may move the bar to seek at any location of the track.

(4) Hour Buttons Select and click to playback the recorded video file on the specific time frame.

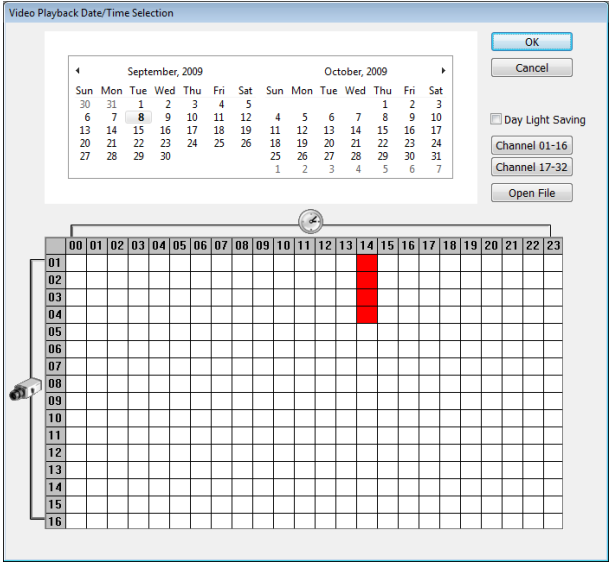

The Hour buttons represent the time in 24-hour clock. The blue bar on top of the hour button indicates that there is a recorded video file on that period of time. If there is no recorded data within the hour, there will be no color bar on top of the hour button. While the red bar indicates that you are currently viewing the recorded video file.

Name	Function
(5) Playback Control Buttons	<p>⏪ Begin: Move at the beginning of the recorded video file.</p> <p>⏮ Previous: Go back to the previous frame.</p> <p>⏴ Slower: Play the recorded video file at the speed of 1/2x, 1/4x, or 1/8x.</p> <p>⏮ Rewind: Wind back the recorded video file.</p> <p>⏸ Pause: Briefly stop playing the recorded video file.</p> <p>▶ Play: Play the recorded video file.</p> <p>⏴ Faster: Play the recorded video file at the speed of 2x, 4x, or 8x, 16x or 32x.</p> <p>⏭ Next: Go to the next frame.</p> <p>⏩ End: Go to the end of the recorded video file.</p>
(6) Archive	<p>Select the date on the calendar and the time from 00 to 23 to where to start playing the recorded video file.</p> <ul style="list-style-type: none"> – OPEN FILE: Click to open the recorded file from certain location. – Channel 01~ 16 & Channel 17 ~ 32: Click to switch to different channel group of playback calendar if the DVR supports more than 16 channels(EXR DVR doesn't support this function button). – Mark Day Light Saving, the playback calendar will show the available playback records during day light saving period.
	
<p>i The numbers from 00 to 23 represent the time in 24-hour clock. The numbers from 01 to 04 represent the camera ID. While the red colored column indicates on where to start playing the recorded video file. If there is no any video data, it will be no color bar on top of the date button.</p>	
(7) Preview	Switch to Preview mode.
(8) Playback	Switch to Playback mode. This allows you to view the recorded video file.
(9) Status bar	Display the record date, time, HDD capacity in preview mode and play speed in playback mode.
(10) Camera ID	Show the number of cameras that are being viewed. When you are in single screen mode, click the camera ID number to switch and view other camera.
(11) Export	<p>Export includes Snapshot, Print, and Output Video Clip function.</p> <ul style="list-style-type: none"> ▪ Snapshot: Capture and save the screen shot either in *.jpg format. ▪ Print: Print the screen shot. ▪ Output Video Clip: Save the segmented file in *.dvr format (see also Chapter 6.3.1.1).
(12) Segment	Keep a portion of the recorded video you want (see also Chapter 6.3.1.1).

Name	Function
(13) Full screen	View in Playback-compact mode. To return, press the right button of the mouse or ESC on the keyboard.
(14) Event Log	Show the record of activities that take place in the system
(15) Visual Search	Search from a specific camera by Date, Hour, Minute, 10 Seconds and Second(see also Chapter 6.3.1.2)
(16) Find Next	Search for the next event. You can use this when you are using Event Search function.
(17) Intelligent Search	Search the changes in the motion detector frame (See also Chapter 3.7.4).
(18) Audio	Enable/disable volume
(19) De-interlace	To enhance the video quality. Set the de-interlace mode to #1, if you are capturing motionless picture and #2, if it captures lots of movement.

6.3.1.1 To Cut and Save the Wanted Portion of the Recorded Video

1. Use the Playback Control buttons or drag the bar on the playback progress bar and pause on where you want to start the cut. Then, click Segment to set the begin mark.



2. Use the Playback Control buttons or drag the bar on the playback progress bar and pause on where you want to end the cut. Then, click Segment to set the end mark. To cancel segmentation or set the segment marks from the start, click Segment button again.



3. Click **Output** button to save the wanted clip.
4. In the Save As dialog box, locate on where you want to save the file, type the filename, and select the video format.

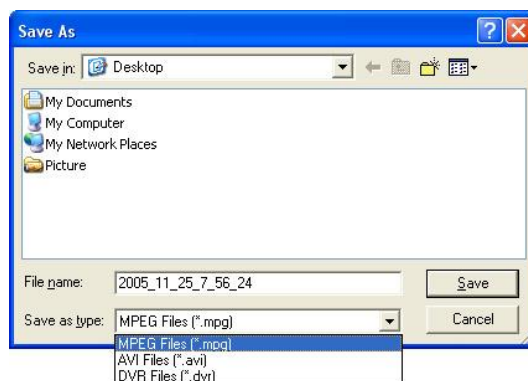

6.3.1.2 To Search Using the Visual Search

1. Click **Visual Search**.
2. In the Visual Search Setting dialog box, select the Camera number and the date. Then click **OK**.



3. When a series of frames appear by date, click on the frame to display another series of frames and search by every Hour of that date, every 3Minutes of that hour, every 10 Seconds of that minute, every Second of that 10 seconds. To go back, click . To view from the selected frame and close event search, click .

6.3.2 Familiarizing the Buttons in RealTime Playback



Name	Function
(1) Split Screen Mode	Select from 6 different split screen type to playback the recorded video file of the entire camera, or one camera.
i	<ul style="list-style-type: none"> - If there are only 4 cameras, you won't be able to switch to 8, 13, and 16 split screen mode. - To zoom in an area on the screen, Right click and Drag a square on the area you want to enlarge.
(2) Exit	To close the application
(3) Progress bar	Show the progress of the file being played. You may move the bar to seek at any location of the track.
(4) Hour Buttons	Select and click to playback the recorded video file on the specific time frame.
i	The Hour buttons represent the time in 24-hour clock. The blue bar on top of the hour button indicates that there is a recorded video file on that period of time. While the red bar indicates that you are currently viewing the recorded video file.
(5) Playback Control Buttons	<ul style="list-style-type: none"> ⏮ Begin: Move at the beginning of the recorded video file. ⏪ Previous: Go back to the previous frame. ⏩ Slower: Play the recorded video file at the speed of 1/2x, 1/4x, or 1/8x. ⏴ Rewind: Wind back the recorded video file. ⏸ Pause: Briefly stop playing the recorded video file. ▶ Play: Play the recorded video file. ⏩ Faster: Play the recorded video file at the speed of 2x, 4x, or 8x, 16x or 32x. ⏴ Next: Go to the next frame. ⏭ End: Go to the end of the recorded video file.

Name	Function
------	----------

- (6) Archive
- Select the date on the calendar and the time from 00 to 23 to where to start playing the recorded video file.
- **OPEN FILE:** Click to open the recorded file from certain location.
 - **Channel 01~ 16 & Channel 17 ~ 32:** Click to switch to different channel group of playback calendar if the DVR supports more than 16 channels(EXR DVR doesn't support this function button).

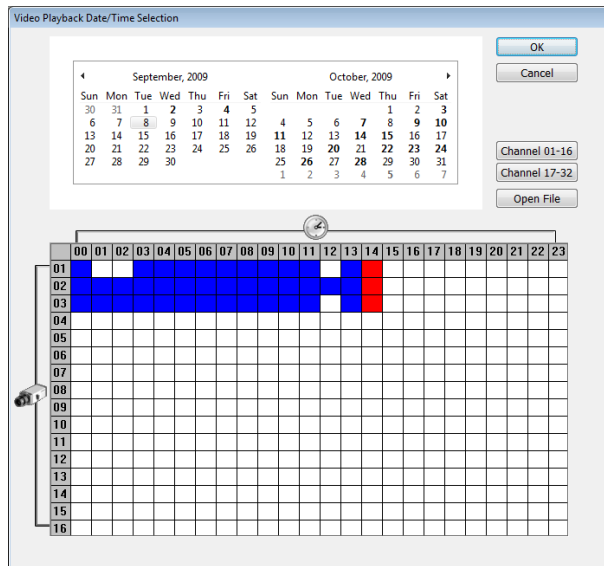

i The numbers from 00 to 23 represent the time in 24-hour clock. The numbers from 01 to 04 represent the camera ID. The blue colored column indicates that there is a recorded video file on that period of time. While the red colored column indicates on where to start playing the recorded video file.

(7) Preview	Switch to Preview/Advanced mode.
(8) Playback	Switch to Playback mode. This allows you to view the recorded video file.
(9) Status bar	Display the recorded date, time and play speed.
(10) Camera ID	Show the number of cameras that are being viewed. When you are in single screen mode, click the camera ID number to switch and view other camera.
(11) Export	Snapshot: Capture and save the screen shot either in *.jpg or *.bmp format.
(12) Full screen	View in Playback-compact mode. To return, press the right button of the mouse or ESC on the keyboard. When you switch to full screen in multiple-screen mode, Left click to toggle to only display one of the video in the multiple-screen mode or all.
(13) Event Log	Show the record of activities that take place in the system
(14) Audio	Enable/disable volume
(15) De-interlace	To enhance the video quality. Set the de-interlace mode to #1, if you are capturing motionless picture and select #2, if it captures lots of movement.

6.3.3 Familiarizing the Buttons in Download and Playback



Name	Function
(1) Exit	To close the application.
(2) Progress bar	Show the progress of the file being played. You may move the bar to seek at any location of the track.
(3) Playback Control Buttons	<p>Begin: Move at the beginning of the recorded video file.</p> <p>Previous: Go back to the previous frame.</p> <p>Slower: Play the recorded video file at the speed of 1/2x, 1/4x, or 1/8x.</p> <p>Rewind: Wind back the recorded video file.</p> <p>Pause: Briefly stop playing the recorded video file.</p> <p>Play: Play the recorded video file.</p> <p>Faster: Play the recorded video file at the speed of 2x, 4x, or 8x, 16x or 32x.</p> <p>Next: Go to the next frame.</p> <p>End: Go to the end of the recorded video file.</p>
(4) Status bar	Display the recorded date, time and play speed.
(5) Language	Customize the system to display the tool tips and dialogs based on the selected language. By default the language is in English.
(6) Export	Export includes Snapshot, Print, and Output Video Clip function. <ul style="list-style-type: none"> ▪ Snapshot: Capture and save the screen shot either in *.jpg or *.bmp format. ▪ Print: Print the screen shot. ▪ Output Video Clip: Save the segmented file in *.mpg, *.avi, or *.dvr format (see also Chapter 6.3.1.1).
(7) Segment	Keep a portion of the recorded video you want (see also Chapter 6.3.1.1).
(8) Full screen	View in Playback-compact mode. To return, press the right button of the mouse or ESC on the keyboard. When you switch to full screen in multiple-screen mode, Left click to toggle to only display one of the video in the multiple-screen mode or all.
(9) Visual Search	Search from a specific camera by Date, Hour, Minute, 10 Seconds and Second. (See also Chapter 6.3.1.2)
(10) Audio	Enable/disable volume
(11) De-interlace	To enhance the video quality. Set the de-interlace mode to #1, if you are capturing motionless picture and #2, if it captures lots of movement.

Chapter 7 Using HandyViewer to Access DVR Server

Users can use a mobile phone to access the DVR through Internet. Make sure your mobile phone support IE browser and is connected to the internet. To access the DVR server, open IE browser and enter **http://enter server IP or domain name here/mobile**. You can see the latest screen shot. Click << >> to change the channel or camera and **Refresh** to reload new screen shot.

7.1 Using PDAViewer to Access DVR Server

Users can also use a PDA to access the DVR through Internet. Make sure your PDA support IE browser and is connected to the internet. To use this feature, you need to install the PDA Viewer software either thru ActiveSync connection or download it from the internet. Please check if your PDA meets the 2 requirements below.

OS: MS Windows CE 4.0, PocketPC 2002/2003, Mobile 5 PDA version
CPU: ARM architecture

7.1.1 To install PDAViewer thru ActiveSync

1. Connect your PDA to your PC. Place the CD into the CD-ROM drive then click Install PDAViewer. And follow the on screen instructions.



2. Click **Next** to continue.

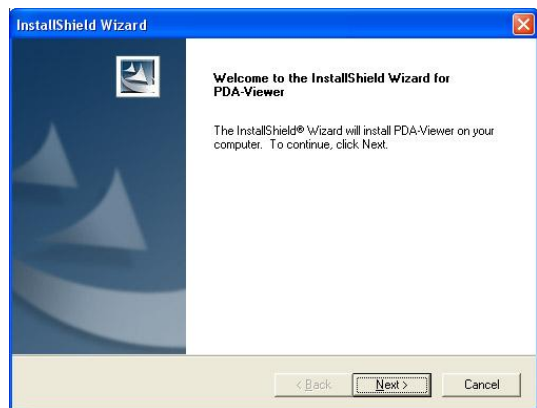

3. Read the license agreement and click **Yes** to accept all the terms. The system will then automatically install the application.



- When you are prompted, click **Yes** to install the application using the default directory.

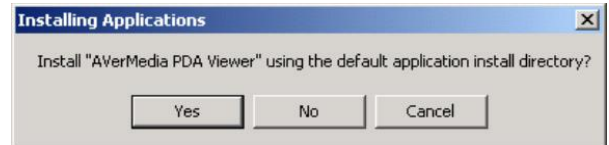

- When done, click **OK**.

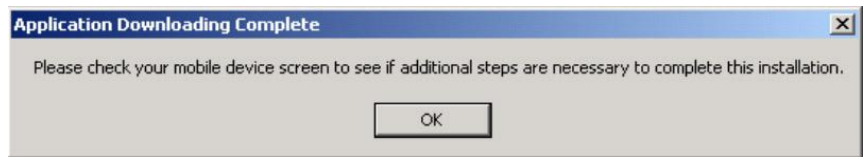

7.1.2 To install PDAViewer from the Internet

Make sure you are connected to the internet.

- Open the web browser and enter the server IP. Then click the hyperlink **Download PDAViewer**.



- When the Download dialog box appears, enable **Open file after download** and click **Yes**.



- After the installation, the PDAViewer icon will appear in the Programs list.



7.1.3 To Use the PDAViewer

1. Run the **PDAViewer** in the Programs.
2. Familiarizing the PDAViewer buttons.

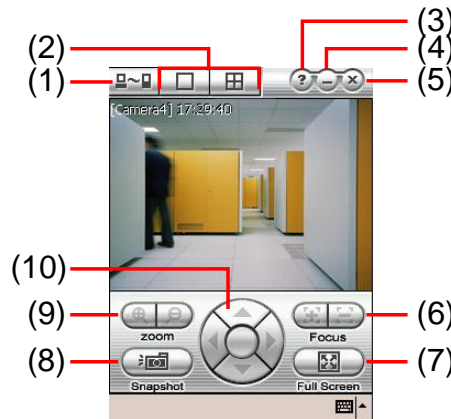

Name	Function
------	----------

(1) Connect Hook up to the DVR server. Make sure you are connected to internet. When the iView screen appears, click Add to add DVR server.

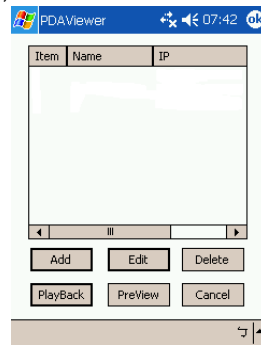

Enter the server IP, port, user ID, password and select the connection type. Then, click **OK**.

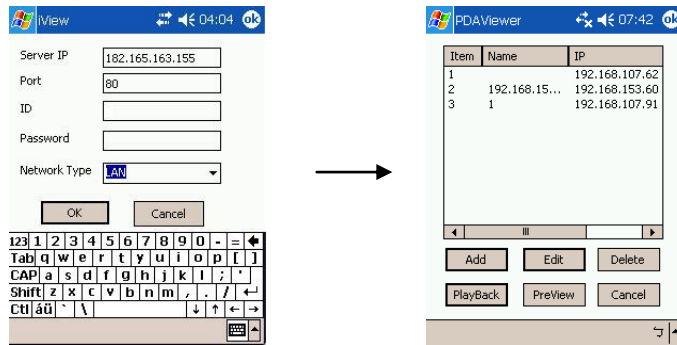

User can playback the recorded video from remote DVR server in PDAViewer.(see also [Chapter 7.1.4](#))

(2) Split Screen Mode	Select between 2 screen display types. It also allows you to switch and view different camera number or channels.
(3) About	Display the PDAViewer software version.
(4) Minimize	Reduce the size to taskbar.
(5) Exit	Close the PDAViewer.
(6) Focus	Adjust the focus of PTZ camera to produce clear image.
(7) Full Screen	Use the entire screen to only display the video.
(8) Snapshot	Capture and save the screen shot in *.bmp format.
(9) Zoom	Zoom in and out the PTZ camera image.
(10) Direction buttons	Adjust and position the focal point of the PTZ camera.

- To change the video quality, enable/disable audio, and select to display different camera, tap on the video screen longer the popup menu will appear.



7.1.4 To Playback in PDAViewer

- Run the **PDAViewer** in the Programs.
- Hook up to the DVR server.
- Click **Connect** icon and select the DVR server
- Click **Playback** to enter playback option screen
- Select the **camera, data, and time**
- Click **Playback** to start playing the recorded video

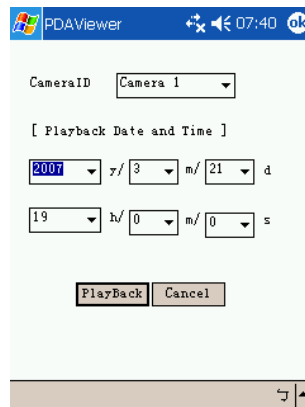

- While playback, user can view and change status of I/O devices
- On the playback screen, tap on video screen longer the pop up menu will appear
- Select the **Remote IO**



- The sensor and relay devices will list as below:

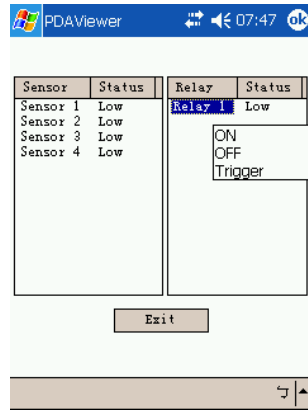

11. User can change the relay status. Select the relay and tap on video screen longer the pop up menu will appear, and then, select the status (ON, OFF, Tigger)

7.2 Using JavaViewer to Access DVR Server

Using the mobile phone within Symbian Smart Phone OS to access the DVR through Internet. Make sure your mobile phone supports Symbian Smart Phone OS and can be connected to the internet. To use this feature, you need to install the JavaViewer program that it can be downloading it from the DVR server through the internet.

7.2.1 To install JavaViewer from the DVR Server

1. Open the web browser and enter the DVR server IP (<http://DVR server IP: port/JAVA-Viewer.html>). Then click **Connect**.
2. When the Download screen appears, select **JAVA-Viewer.jad** and download it to your mobile phone.
3. After the installation, the JavaViewer will be in your mobile phone system. To find the JavaViewer program where is located, please refer to your mobile phone user's manual.

7.2.2 To Use the JavaViewer

1. Run the JavaViewer program.
2. Enter the DVR IP address, port number, user ID, and password. Please refer to your DVR server setting for that information.
3. And then, select the Connect to connect to DVR server.
4. Click **Yes** to accept the data from DVR server.
5. When connection is success, you will see the camera video on the screen.
6. To switch to different camera view, select menu and select the channel.



7. The JavaViewer support PTZ control function, you can refer to **Help** file for detail function control key. Select **menu** and go the way down to select the **Help** file.



Chapter 8 Web Tools

The bundled Web Tools includes Dispatch Server , Remote Backup, and Remote Setup program. To install Web Tools, place the CD into the CD-ROM drive then click **Install Web Tool**.

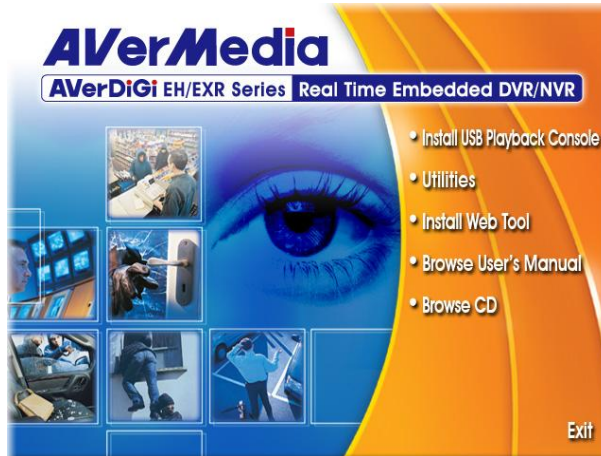

8.1 Dispatch Server

Dispatch is designed to reduce the network traffic of the DVR server. Instead of connecting directly to the DVR server, the client can connect to the computer that is connected to the DVR server using the Dispatch program.

8.1.1 To Run Dispatch program:

1. Make sure you are connected to the internet.
2. Click **Start>Programs>Web Tool>Dispatch**.
3. In the DVR Server section, enter the DVR server IP, port, user ID and password. You can also select to display the language you prefer.
4. **Auto connect when start:** Enable to automatically connect the dispatch server when start up
5. **3GPP Service**
6. Enable to allow user using 3GPP service to receive video stream from Dispatch server. The **Service Port** must same as RTSP port of 3GPP on DVR server.
7. In the **Dispatch Service** section, if you have installed more than one network card, select the Service IP number.
8. In the **Dynamic DNS Configuration** section, enter the DNS server Name and Password. The DNS server can be the remote storage server for sharing the DVR system loading.
9. Click **START** to connect.

8.2 Remote Setup

Remote Setup is a tool for configuring DVR server from remote site. To install Remote Setup application, insert the Installation CD into CD-ROM drive and click **Install Web Tool**. After installation, click  to start the Remote Setup application.

8.2.1 To Add DVR server

User need to add a DVR server and make connection in order to setup remote DVR server.

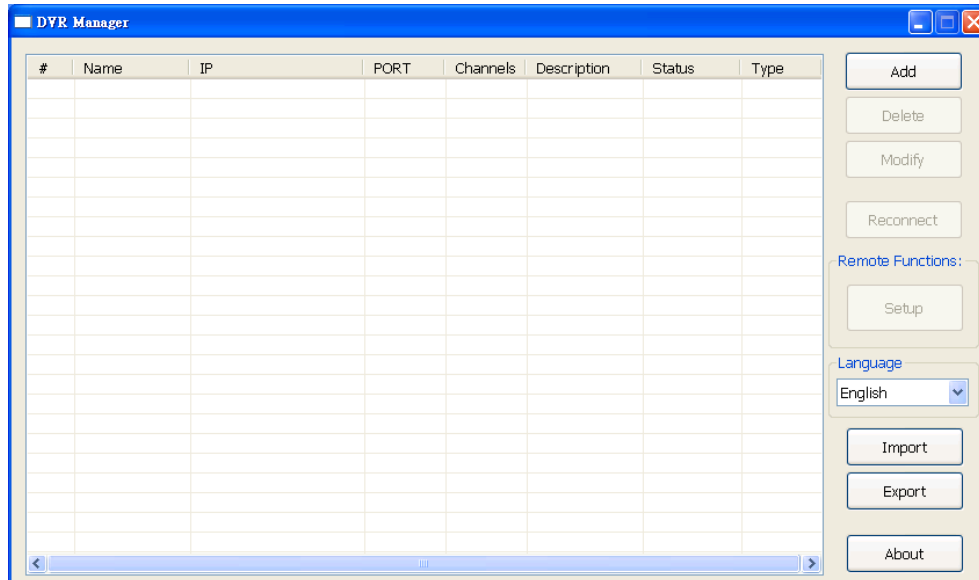

1. Click **Add**
2. In Edit DVR window, fill in the following items:
 - **Name:** give a name for remote DVR server for easy managing
 - **IP:** fill in remote DVR server's IP address
 - **Port:** the port use to connect to remote DVR server. The port number is same the Webviewer port on the remote DVR server. The default is 80.
 - **User ID:** fill in the remote DVR server's login account
 - **Password:** fill in the remote DVR server's login password
 - **Description:** fill in a short description for the remote DVR server

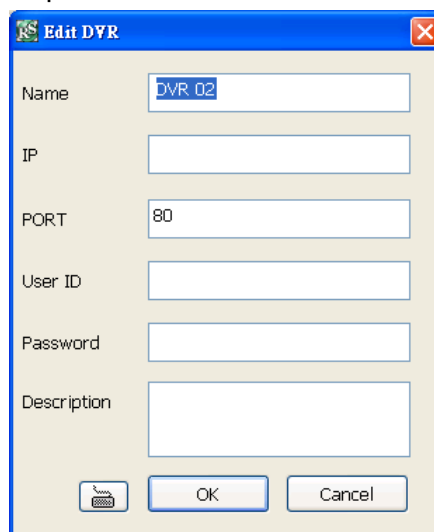

3. Click **OK** to complete adding remote DVR server.
4. The added DVR server will be listed and auto connects to DVR server.
5. Once the connecting is success, user can start to configure DVR server.

6. When connection is lost, click **Reconnect** to connect again.
7. To modify or delete the added DVR server, select the DVR server from listing and click **Modify** to change the setting and click **Delete** to remove the DVR server.
8. User also can import the setting by clicking **Import** button. To save the setting to local hard disk, click **Export** button.

8.2.2 To Setup Remote System Setting

The setting here applies to Remote DVR only.

8.2.2.1 System Setting

In the System Setting window, click **Update** to accept the new settings, click **Exit** to exit without saving, and click **Default** to revert back to original factory setting.

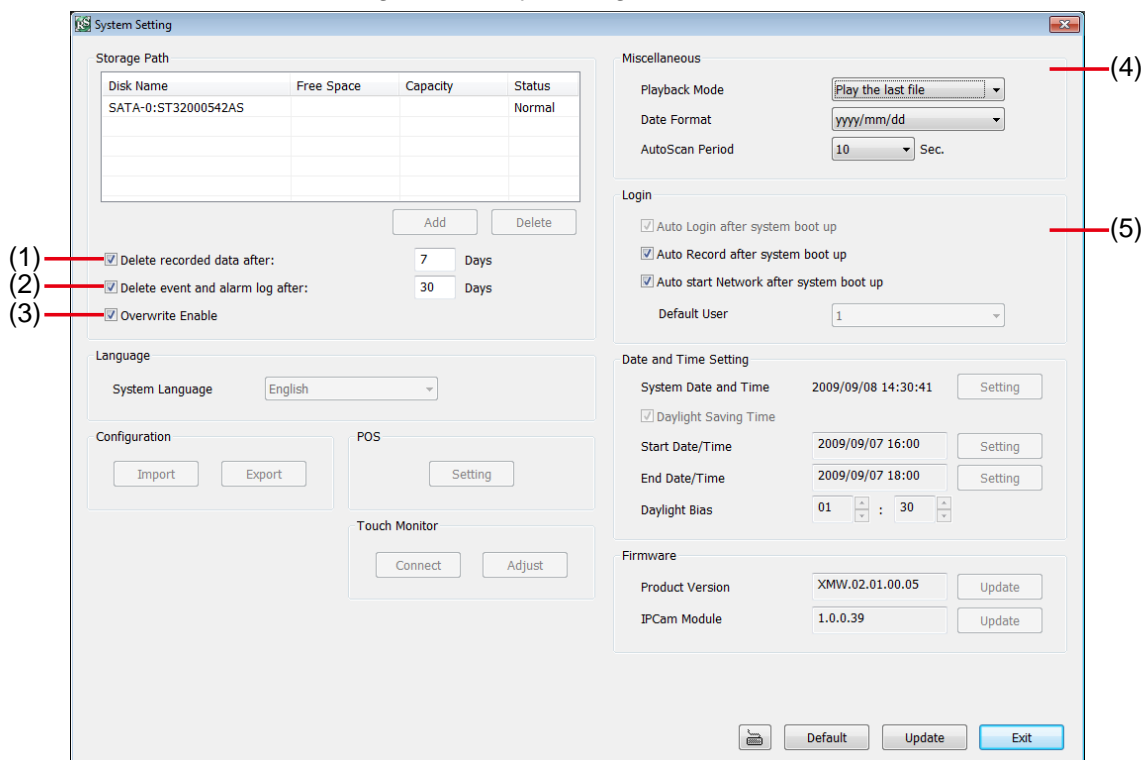

(1) Delete recorded data after

If you want the system to automatically erase the data after a certain days, enable the **Delete recorded data after** check box and enter the numbers of days in **Days** text box.

(2) Delete event and alarm log after

If you want the system to automatically erase the event and alarm log files after a certain days, enable the **Delete event and alarm log after** check box and enter the numbers of days in **Days** text box.

(3) Overwrite Enable

When there is not enough free space to record one hour data, the system automatically replaces the oldest data.

(4) Miscellaneous

Enable the conditions in **Miscellaneous** section you want the system to perform.

- Playback Mode

Select the mode of playback the video.

✓ **Select date and time:** Select the date and time which user wants to playback.

✓ **Play the last file:** Automatically playback the video from the last hour

✓ **Instant Playback:** Automatically playback the video which has just recorded

- Date Format

Select the date format which wants to display in **Select date and time** playback mode

- **Auto Scan Period**

Set the time gap of the Auto Scan function from 3 to 10 seconds. This automatically switches to the next video in cycle depending on the set time gap.

(5) Login

Enable the conditions in Login section you want the system to automatically carry out.

- **Auto Record after system boot up**

Automatically start video recording when the DVR is executed.

- **Auto start Network after system boot up**

Automatically connect to network when the DVR is executed.

8.2.2.2 Camera Setting

Select the camera from remote DVR servers to modify settings. In the Camera Setting window, click **Update** to save and apply the new settings, click **Exit** to exit without saving.

IP Camera Setting

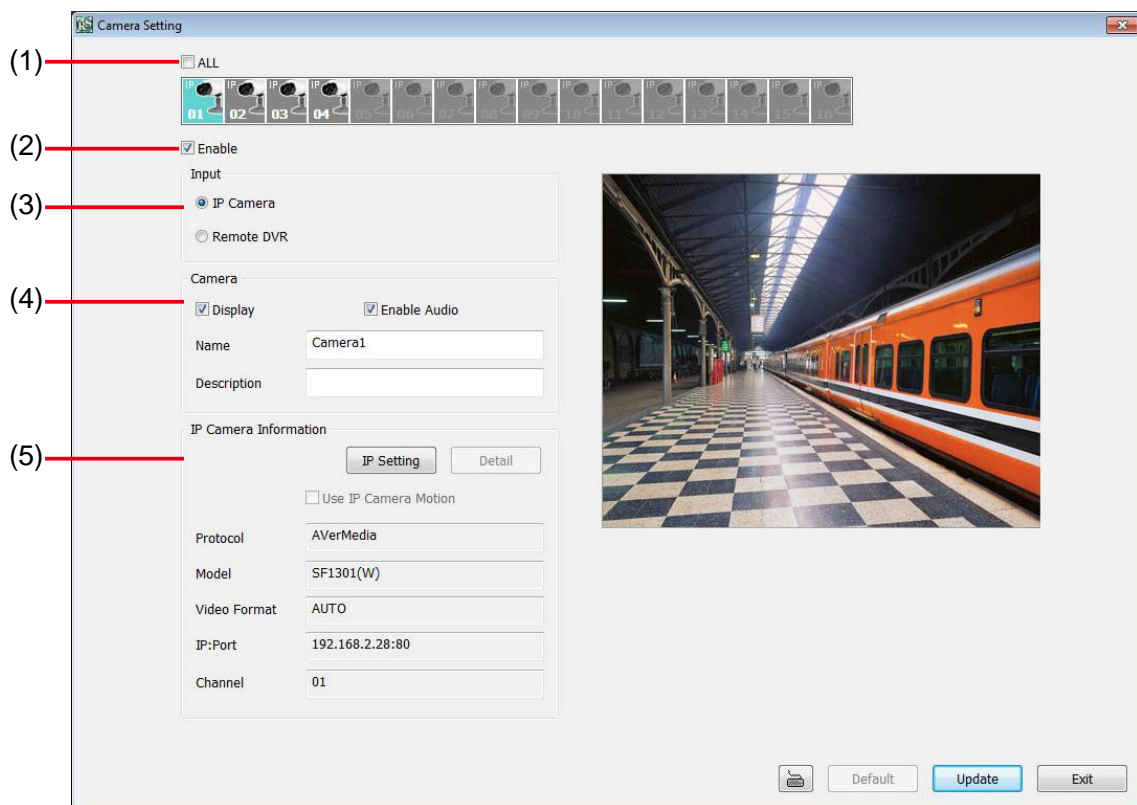

(1) Camera Icons

Select the camera number you want to adjust the video setting. To select all the cameras, enable the **ALL** check box. To select more than one camera, Right click on the camera icon. To select one camera only, Left click on the camera icon. The camera icon turns red when it is selected.

(2) Enable

Set to enable/disable the selected camera. When there is no video source on the camera, we suggest disabling it so that the system won't detect it as video loss error.

(3) Input

Select the type of camera as IP camera. To modify camera of remote DVR, see [Remote DVR Camera Setting](#).

(4) Camera

- **Display**

Enable/disable to show the video. Even if the video of the selected camera is hidden you can still record the video and preview it in playback mode.

- **Enable Audio**

Enable/disable audio of the camera.

- **Name**

Change the camera name

- **Description**

Add a short comment

(5) IP Camera Information

Click **IP setting** to view IP camera's detail information. User can view current connected wireless IP camera information such as **Protocol**, **Model**, **Video Format**, **Channel**, and **IP Camera Site**(IP address of IP camera). If wireless IP camera has enabled the authentication, user can mark **Authentication** check box and enter the **ID** and **password** of the IP camera. The **URL** is not supported in here.

To exit the IP Camera Settings windows, click **OK** to save the changes and exit. Click **Exit** will not save any changes and exit.

The screenshot shows a window titled "IP Camera Settings" with a close button in the top right corner. The window is divided into two main sections. The top section, "IP Camera Information", contains several dropdown menus: "Protocol" (set to "AVerMedia"), "Model" (set to "SF1301(W)"), "Video Format" (set to "AUTO"), and "Channel" (set to "1"). To the right of the "Protocol" dropdown is a "Search Devices" button. Below these is the "IP Camera Site" field, which contains "192.168.2.28" and "80" separated by a colon. The bottom section contains two radio buttons: "Protocol" (selected) and "URL". Below the "URL" radio button is a text field with "http://" and an empty input box. There is also a checked checkbox for "Authentication". Below this checkbox are two text fields: "ID" (containing "admin") and "Password" (empty). At the bottom right of the window are "OK" and "Cancel" buttons.

Remote DVR Camera Setting

Select the camera to modify settings. In the Camera Setting window, click **Update** to save and apply the new settings, click **Exit** to exit without saving.

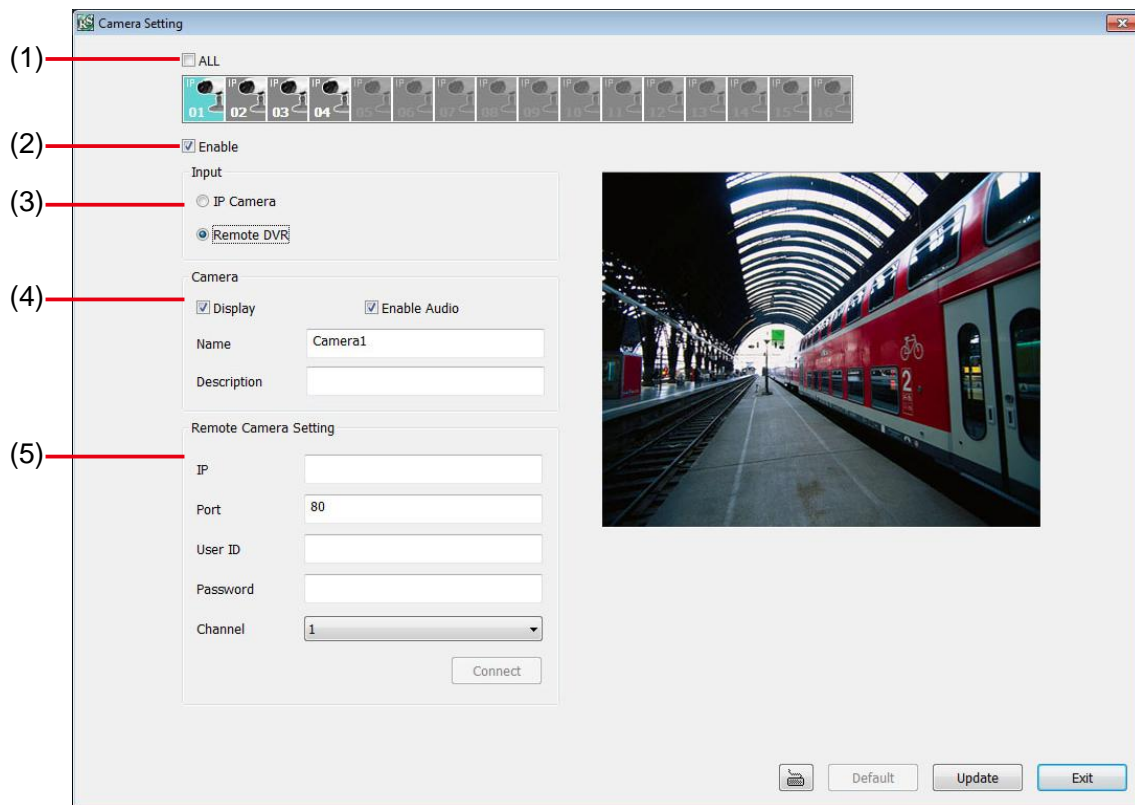

(1) Camera Icons

Select the camera number you want to view. To enable/disable all cameras, click **ALL** check box.

(2) Enable

Set to enable/disable the selected camera. When there is no video source on the camera, we suggest disabling it so that the system won't detect it as video loss error.

(3) Input

Select the camera type as **Remote DVR**. For IP camera setting, see [IP Camera Setting](#).

(4) Camera

- **Display**
Enable/disable to show the video. Even if the video of the selected camera is hidden you can still record the video and preview it in playback mode.
- **Enable Audio**
Enable/disable audio of the camera.
- **Name**
Change the camera name
- **Description**
Add a short comment
- **IP**
Enter the IP address of the camera
- **Port**
The port for connection
- **User ID**
Enter the user id that for connecting authority
- **Password**
Enter the password that is for connecting authority
- **Channel**
Select the channel of connected camera

8.2.2.3 Record Setting

In the Recording setup window, click **OK** to accept the new settings, click **Exit** to exit without saving, and click **Default** to revert back to original factory setting.

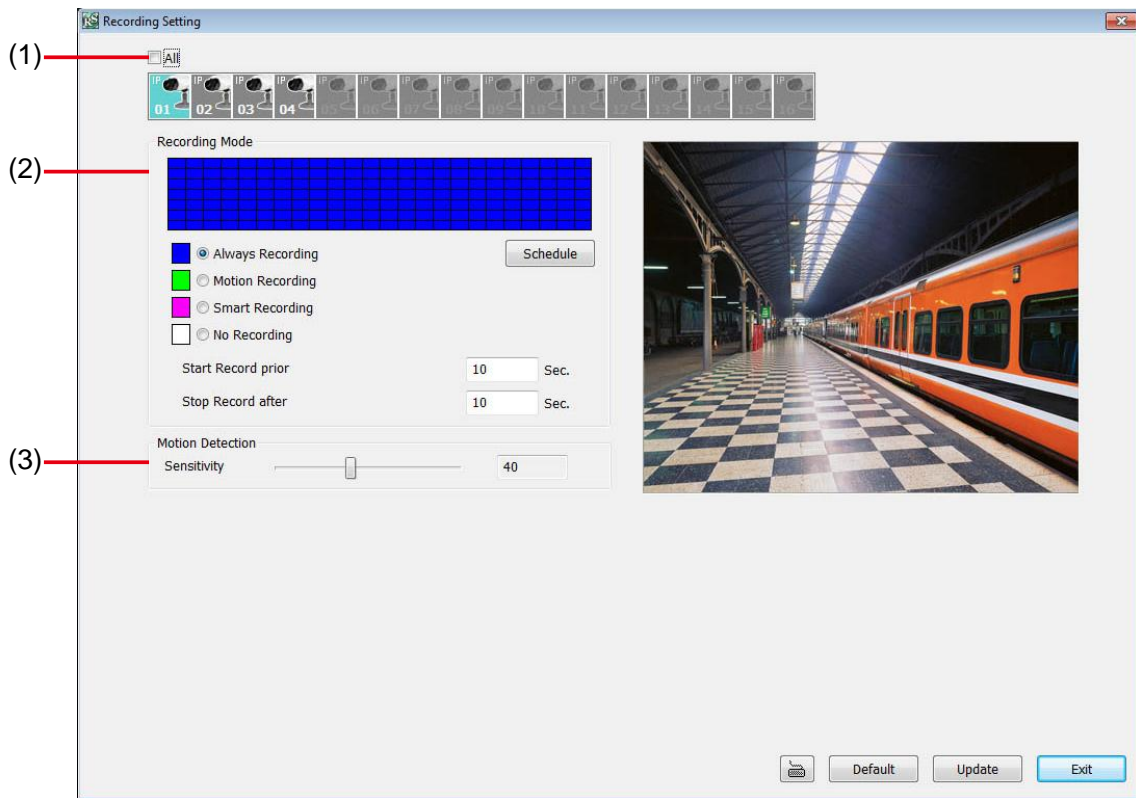

(1) Camera Icons

Select the camera number you want to set the recording setting. To select all the cameras, enable the **ALL** check box. To select more than one camera, **Right click** on the camera icon. To select one camera only, **Left click** on the camera icon. The camera icon turns purple when it is selected.

(2) Recording Mode

The horizontal blocks from 00 to 23 represent the time in 24-hour clock and the vertical block 1 to 7 represent the day in the week block (Sunday to Saturday). To record in full 24 hours and 7 days a week, select the recording mode and click the button. If you want to only record at a particular time or day, click **Schedule** button and select the **Recording Mode**, and then click on the time or day blocks. When the system starts recording a red triangle mark would appear at the upper left corner of the screen.

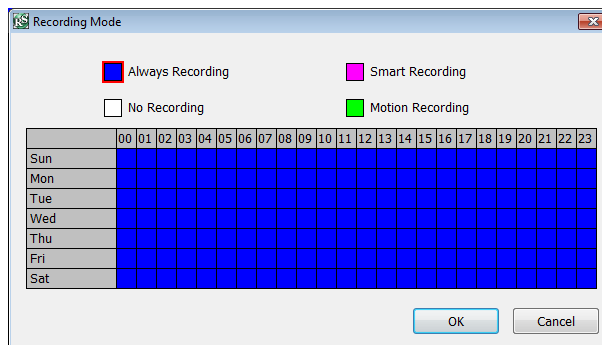

The recording modes are listed below:

- **Always Recording**
Record the video from the selected camera and save it to the designated storage path
- **Motion Recording**
Start recording the video from the selected camera only when the system detects movement. Once a motion is detected, the system automatically saves the previous frames and stop based on the **Start Record Prior** and **Stop Record After** settings.

- **Smart Recording**

Automatically switch to recorded at the maximum frame rate setting once a motion is detected and if there is no motion, it records at the minimum frame rate setting.

- **No Recording**

The system won't do any recording.

(3) Motion Detection

Adjust the sensitivity of the motion detection. The higher the value, the finer the sensitivity is detected. When it detects a motion, a green triangle mark would appear at the upper left corner of the screen.

8.2.2.4 Network Setting

In the Network Setting dialog box, click **Update** to accept the new settings, click **Exit** to exit without saving, and click **Default** to revert back to original factory setting. For the network service ports that use by DVR server, please see [Appendix A](#).

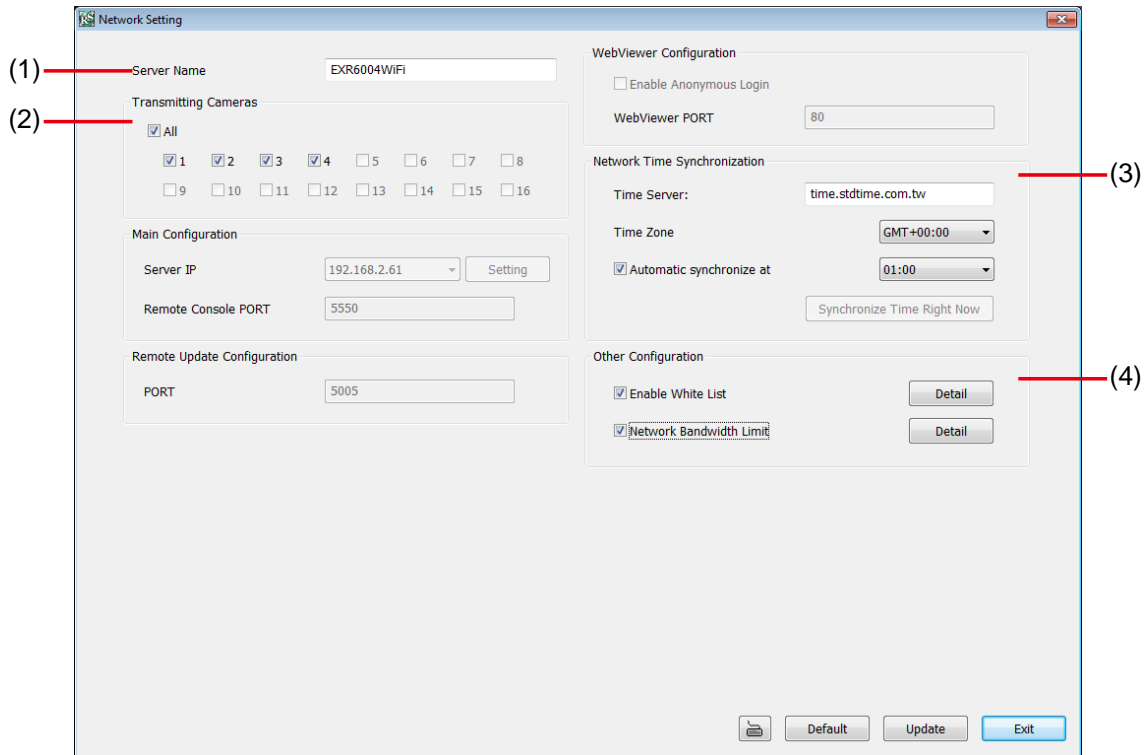

(1) Server Name

Assign a name for the DVR unit. Alphabet letters and numbers only.

(2) Transmitting Cameras

Select and click on the camera number in the Transmitting Camera section you want to make it accessible via internet using WebViewer, Remote Console, PDA Viewer and JAVAViewer (still image). To select all the cameras, enable the **ALL** check box.

(3) Network Time Synchronization

Adjust the DVR system time same as network time server. Fill in the **Time Server** IP address or domain name. Select the **Time Zone** that DVR is located. And then, mark the **Automatic Synchronize** time to set automatic synchronize time on a daily basis.

(4) Other Configuration

- Enable White List

An access permit list for the remote accessing of DVR server. Enter the IP address and click **Add**. Or, enter a range of IP address and click **Add**. To delete the IP from the list, select the IP and click **Delete** button. To reset the input, click **Clear** button.

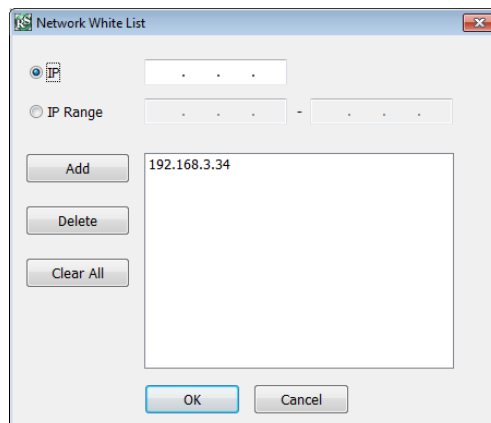

- **Network Bandwidth Limit**

By Channel: Set the network bandwidth by each channel.

All: Set the total network bandwidth consumption limit.

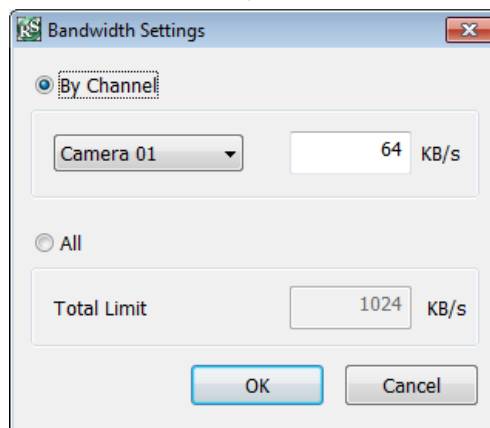

8.2.2.5 Alarm Setting

In the Alarm Setting dialog box, click **Add** to insert and set new alarm setting, click **Delete** to remove the selected alarm setting, click **Update** to save the setting, **Exit** to exit without saving, and **Default** to revert back to original factory setting.

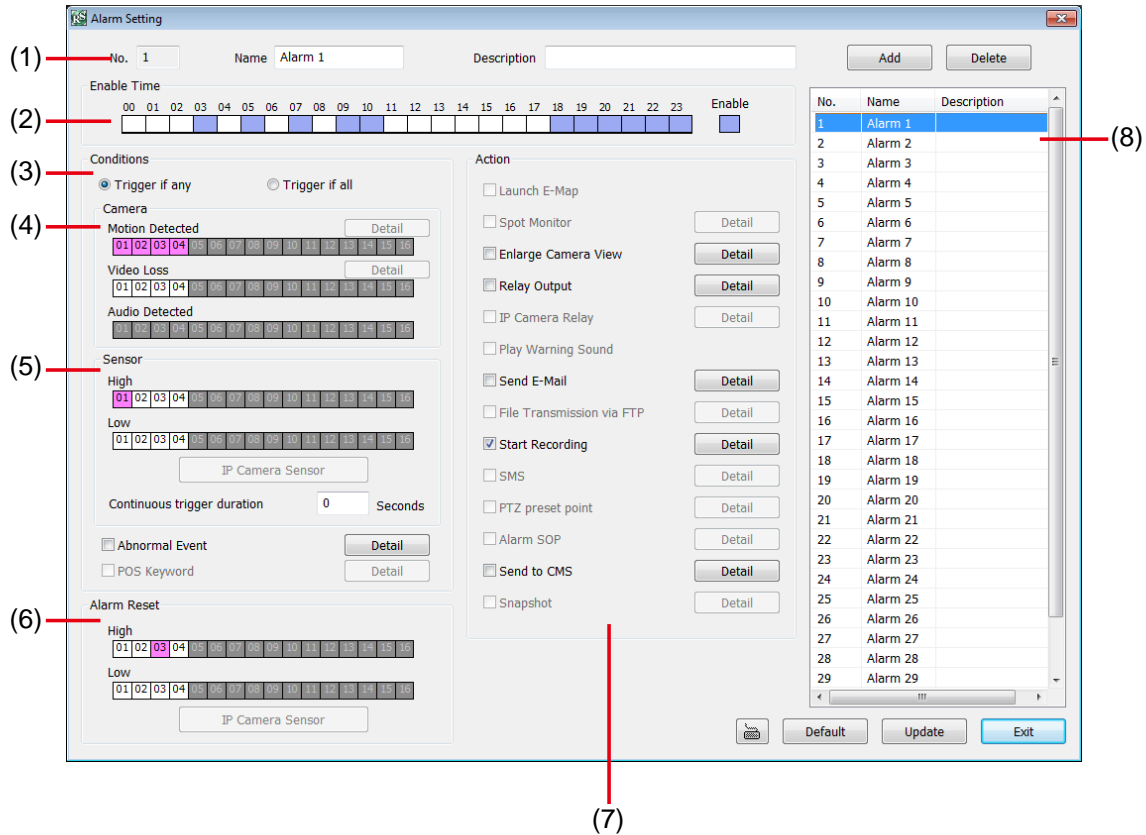

1. Click **Add** to insert and set a new alarm setting. Click the items in the **(8) Alarm Setting List** if you want to modify the alarm setting.
2. In **(1) No./Name/Description** enter alarm name and description. Alarm **No.** will be created by DVR system.
3. In **(2) Enable Time**, the number from 00 to 23 represent the time in 24-hour clock. Select the time and click the block you want to activate or deactivate the alarm function. When it is deactivated the color of the block turns white.
4. In **(3) Conditions**, you can set “**Trigger if any**” to activate if it falls to one of the conditions or “**Trigger if all**” to activate if it falls to all conditions.
5. In **(4) Camera** section, select and click on the camera number (01 to 04) in **Motion Detected** and **Video Loss** to set the condition for the system to alarm.
6. In **(5) Sensor**, select and click on the sensor number to set the condition for the system to alarm. If the sensor normal status is high, set the sensor condition to low.
 - Enable/disable the **Abnormal Event** check box, to set the condition of the event for system to alarm.

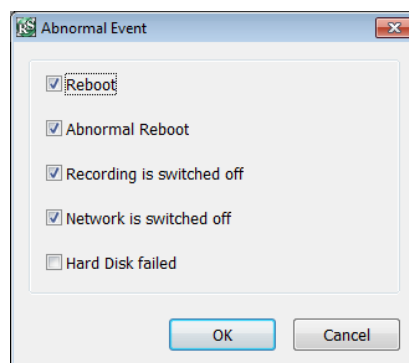

- **Reboot:** when the DVR system reboot without abnormal condition, the system will send out the alarm message.
- **Abnormal Reboot:** when the DVR system reboot in irregular condition, the system will send out the alarm message.
- **Recording is switched off:** when the recording has been stopped, the system will send out the alarm message.
- **Network is switched off:** when the network connection of DVR system is lost, the system will send out the alarm message.
- **Hard Disk failed:** when the hard disk doesn't work normally, the system will send out the alarm message.

- **Continue trigger duration:** Set a time period that when sensor has been trigger and stay in the same status for that period, then the alarm will be sent out.

7. In **(6) Alarm Reset**, click the camera number to set the reset condition of alarm. Once alarm is reset, all alarm action will stop at the moment. If the sensor normal status is high, set the alarm reset condition to low.
8. In **(7) Action**, you may now set the alarm action for the system to perform when the alarm condition is activated.

- **Enlarge Camera View**

Switch to only display video in Preview mode from where the alarm is activated.

- a. Select the camera from drop down list to specify which camera video to be enlarged on screen when the alarm is triggered.
- b. **Retrieve time:** set the waiting duration before system switching back to original Preview mode. If the retrieve time is un-mark, the alarm video will keep enlarging until user switch back to Preview mode manually. The retrieve time range is 0~ 600 seconds.

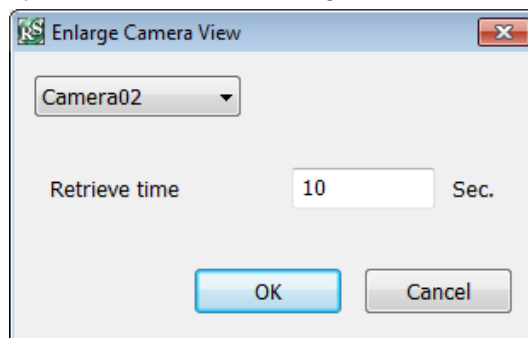

- **Relay Output**

Set to enable/disable the relay operation when the alarm is activated and to extend additional time in second before it stops the relay operation.

1. Beside the Relay Output check box, click **Detail**.
2. In the Alarm Relay dialog box, select from the available relay list and in the ON column, set to enable/disable the relay operation when the alarm is activated.
3. In the Retrieve time check box, you may enable/disable to extend the relay operation time and set the duration in second.
4. Click **OK** to exit and accept the setting and **Cancel** to exit without saving the setting.

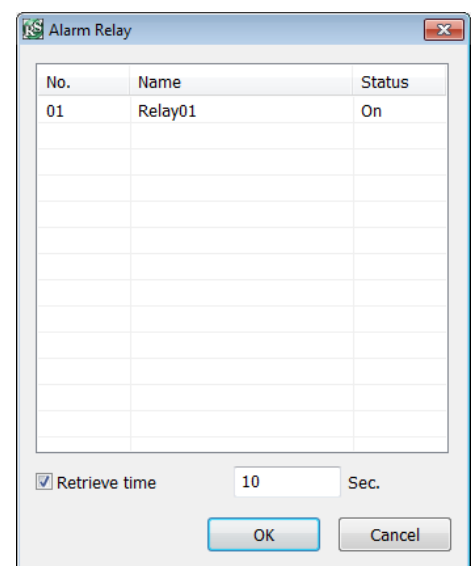

- **Send E-mail**

Send an electronic text message. Beside the Send Email check box, click **Detail**.

In the E-mail Setting dialog box, click **OK** to exit and save the setting and **Cancel** to exit without saving the setting.

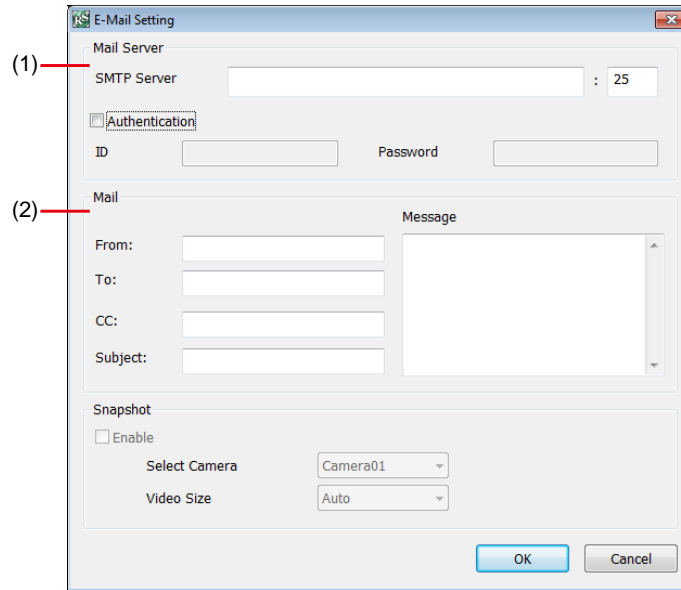

(1) Mail Server

Enter the **SMTP Server** and **port**. If your e-mail system requires user identification, enable **Authentication** check box and enter **ID** and **Password**.

(2) Mail

Fill the mailing information.

From: Enter the sender e-mail address.

To and CC: Enter the recipient email address and separate it with comma or a semicolon (;).

Subject: Enter the message title.

Message: Type the message.

- **Start Recording**

Record the video from the selected camera.

1. Beside the Start Recording check box, click **Detail**.

2. In the Alarm Recording Setting dialog box, select the camera to enable/disable video recording. Enable **All** to select all cameras.

3. In the Frame Rate selection, select **As Setting** to record the number of frames based on the Recording Setting.

4. In the **Start Record prior** text box, mark and set the number in second for the program to begin recording after the alarm has been trigger. The time range is 1~10 seconds.

5. In the **Stop Record after** text box, mark and set the number in second for the program to continue recording after the alarm has ended. The time range is 1~999 seconds. If user doesn't mark and set the time, the alarm recording will continue recording until alarm is reset.

6. Click **OK** to accept the new settings and **Cancel** to exit without saving.

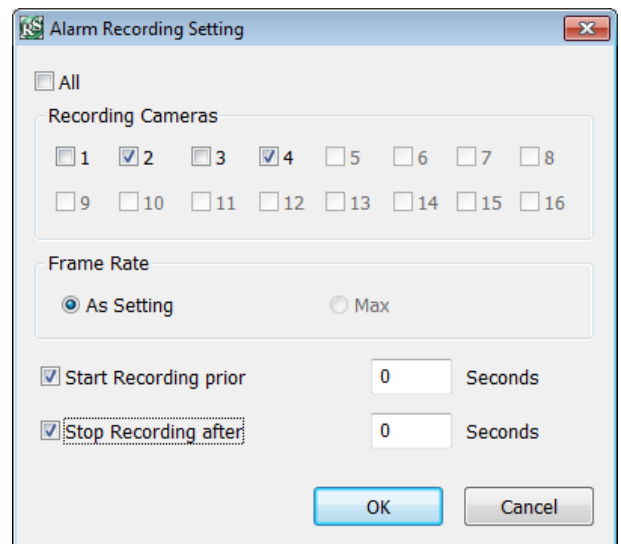

- **Send to CMS (Central Management System)**
Enable/disable the selected camera to send video to CMS when the alarm is activated. Beside the Send to CMS check box, click **Detail**. In the CMS Setting, select the camera to enable/disable sending the video to CMS. Enable **All** to select all cameras. Then, click **OK** to accept the new settings and **Cancel** to exit without saving.

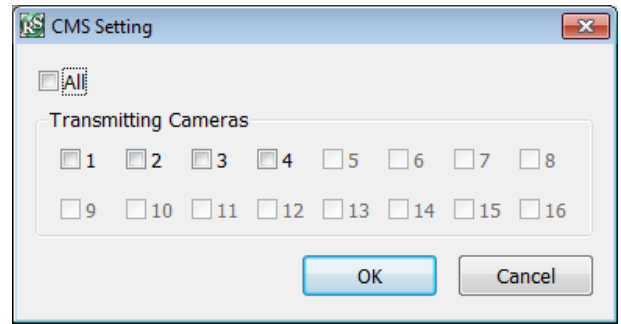

8.3 Remote Backup

Remote Backup is purely for backing up the *.dvr file from the DVR sever. You can select between Auto Backup and Manual Backup. Auto Backup continuously archives one hour of the recorded data at a time, starting from the specified date. As for Manual Backup, it only archives the recorded data of selected date.

i To back up the data, you must have at least 2G hard disk space.

8.3.1 To back up the recoded data from the DVR server:

1. Make sure you are connected to the internet.
2. Click **Start >> Program >> Web Tool >> Remote Backup**
3. To add the DVR server, click **Add**

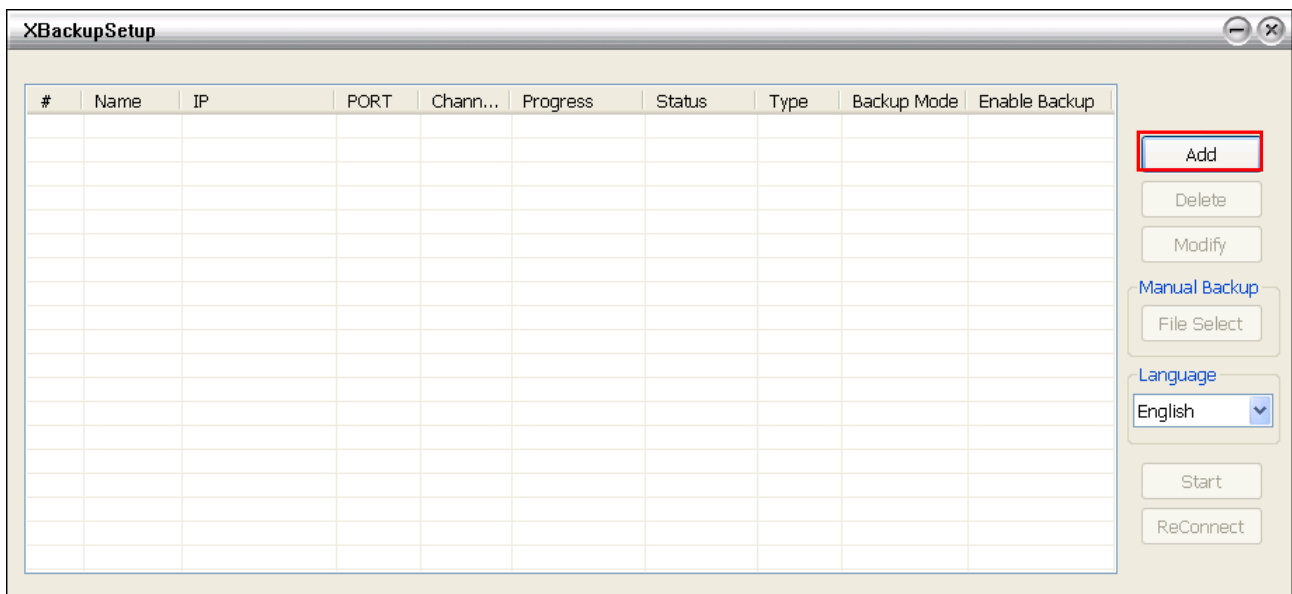

4. In the Add New DVR window, enter the Name, IP, user ID, and password.

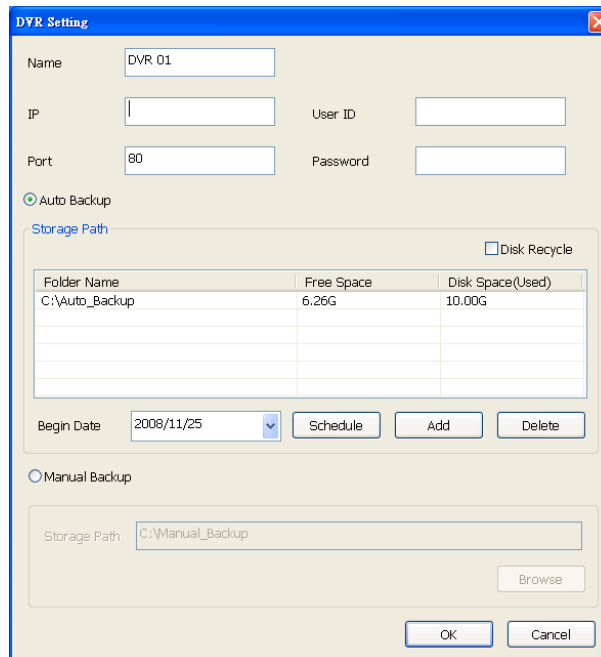

5. Select the Backup mode:
 - Auto Backup mode:** the backup will automatically execute when the setup is completed
 - In Begin Date drop down calendar, select the date from where to start
 - Click **Add** to set the storage path.
 - Click **Delete** to remove the selected storage path.

- Click **Schedule** to select/unselect the time you want to backup. The red block turns white when it is unselected.
- Enable/disable **Disk Recycle** check box, to automatically overwrite the oldest file when there is not enough free space to backup the file.

Manual Backup mode: the backup progress will start when user press the backup button

- Click **File Select** to choose the date, time and camera you want to back up.
 - Click **Browse** to set the storage path.
6. Click **OK** to complete the adding DVR server. The added DVR server will display in Remote Backup main window.

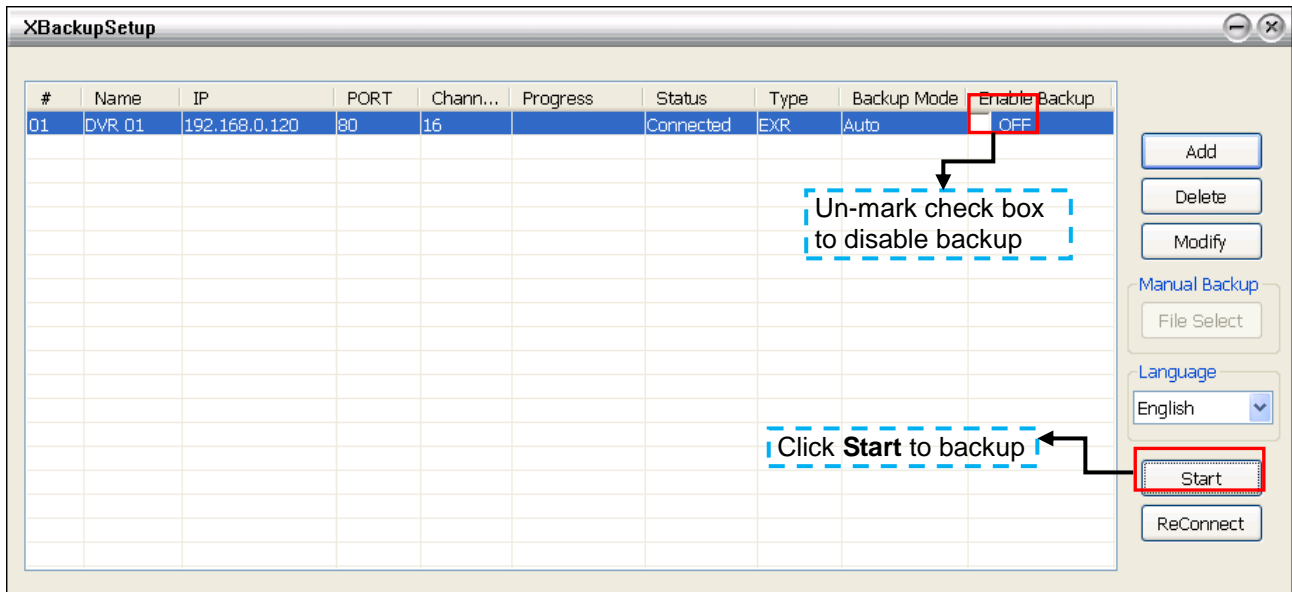

7. Click **Start** to begin backup and click Stop to stop backup progress.

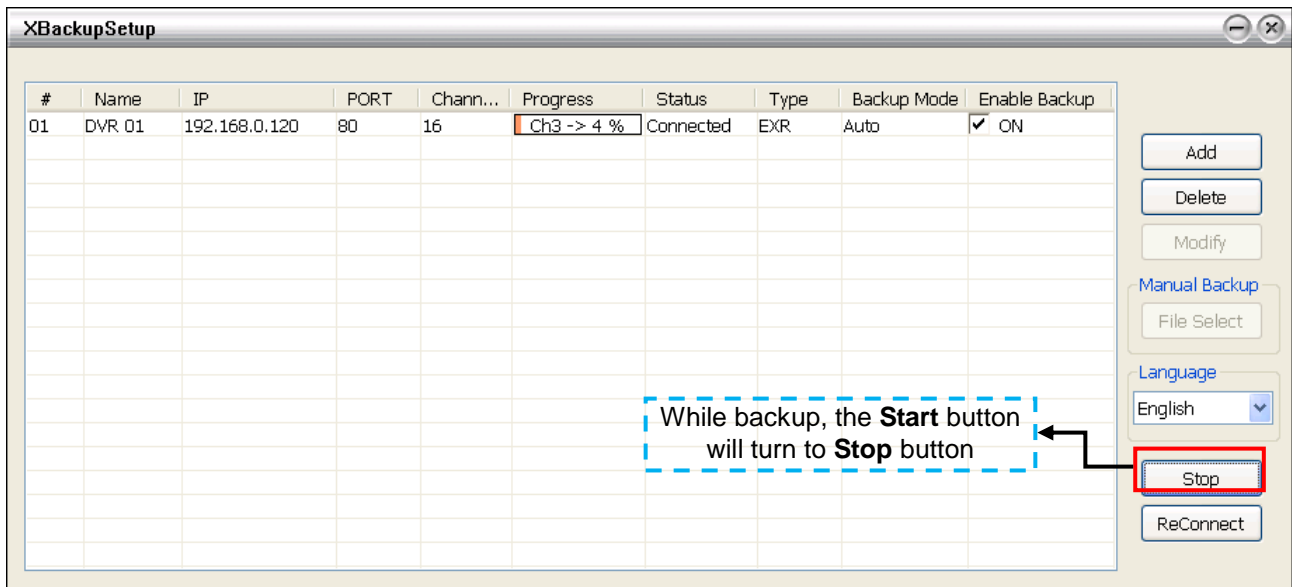

Appendix A Registering Domain Name

DDNS (Dynamic Domain Name Service) is a data query service mainly used on the Internet for translating domain names into Internet addresses. It allows remote clients to intelligently search dynamic servers without any previous enquiring for servers' Internet addresses.

In order to take advantage of this intelligent service, first register your domain name on the following Web site <http://ddns.avers.com.tw>

1. User Login

Browse the website ddns.avers.com.tw with Microsoft IE or Netscape Navigator to access the following dialog.

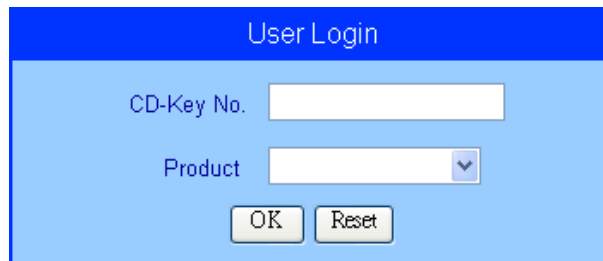

The 'User Login' dialog box has a blue header with the title 'User Login'. Below the header, there are two input fields: 'CD-Key No.' with a text box containing an empty field, and 'Product' with a dropdown menu. At the bottom of the dialog, there are two buttons: 'OK' and 'Reset'.

2. First input the MAC address of DVR unit as the CD-Key No. and select the product name. Then click **OK** to login or **Reset** to clear the previous input.



- To know the MAC address of DVR unit, please check the sticker on the back panel of DVR unit.
- Also, user can find the MAC address of DVR unit from the Main Configuration of Network Setting. Please select **SETUP** → **NETWORK** → **Main Configuration**.

3. User Information

Please provide the following user information, **Host Name** (user can choose any name he/she likes except the one violence with other users), **Password**, **E-mail**, **Company**, and **Country**. And then, click **OK** to complete the domain name registration.

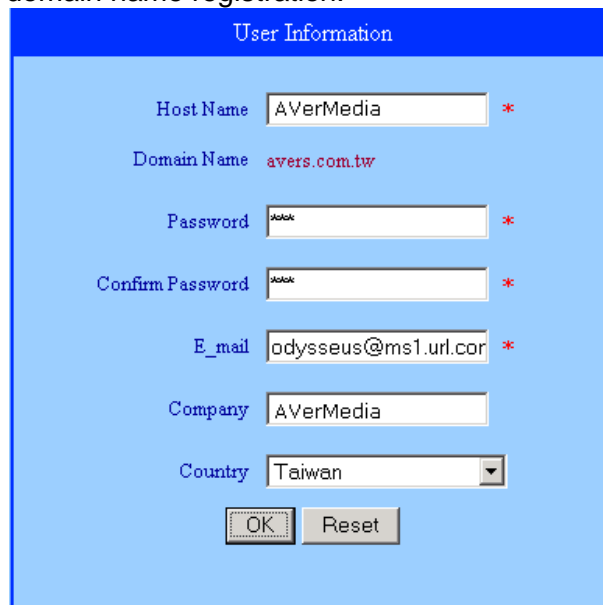

The 'User Information' dialog box has a blue header with the title 'User Information'. Below the header, there are several input fields: 'Host Name' with a text box containing 'AVerMedia' and a red asterisk; 'Domain Name' with a text box containing 'avers.com.tw'; 'Password' with a text box containing '*****' and a red asterisk; 'Confirm Password' with a text box containing '*****' and a red asterisk; 'E_mail' with a text box containing 'odysseus@ms1.url.cor' and a red asterisk; 'Company' with a text box containing 'AVerMedia'; and 'Country' with a dropdown menu showing 'Taiwan'. At the bottom of the dialog, there are two buttons: 'OK' and 'Reset'.

Warranty Notice

LIMITED WARRANTY

AVerMedia Information, Inc. warrants this product to be free of defects resulting from faulty manufacture or components under the following terms:

WARRANTY LENGTH

Labor is warranted for (1) one year from the date of purchase

Parts are warranted for (1) one year from the date of purchase

Replacement products will be warranted for the remainder of the one year warranty period or (30) thirty days, whichever is longer

WHO IS PROTECTED

This warranty is enforceable only by the first consumer purchaser

WHAT IS AND IS NOT COVERED

Except as specified below, this warranty covers all defects resulting from faulty manufacturing of this product. The following are not covered by the warranty.

1. Any product on which the serial number has been defaced, modified, or removed
2. Damage, deterioration, or malfunction resulting from:
 - Accident, abuse, misuse, neglect, fire, water, lightning, or other acts of nature, commercial or industrial use, unauthorized product modification, or failure to follow instructions included with the product.
 - Misapplication of service by someone other than the manufacturer's representative
 - Any shipment damages (Claims must be made with carrier)
 - Any other cause which does not relate to a product defect
3. Cartons, cases, batteries, cabinets, tapes, or accessories used with product
4. AVerMedia does not warrant that this product will meet your requirements; it is your responsibility to determine the suitability of this product for your purpose

WHAT WE WILL AND WILL NOT PAY FOR

We will pay labor and material expenses for covered items. However, we will not pay for the following:

1. Removal or installation charges
2. Shipping charges
3. Any incidental charges

EXCLUSION OF DAMAGES

THE MANUFACTURER'S SOLE OBLIGATION AND LIABILITY UNDER THIS WARRANTY IS LIMITED TO THE REPAIR OR REPLACEMENT OF A DEFECTIVE PRODUCT AT OUR OPTION. THE MANUFACTURER SHALL NOT, IN ANY EVENT, BE LIABLE TO THE PURCHASER OR ANY THIRD PARTY FOR ANY INCIDENTAL OR CONSEQUENTIAL DAMAGE (INCLUDING, BUT NOT LIMITED TO, DAMAGES RESULTING FROM INTERRUPTION OF SERVICE AND LOSS OF BUSINESS) OR LIABILITY IN TORT RELATING TO THIS PRODUCT OR RESULTING FROM ITS USE OR POSSESSION.

LIMITATIONS OF IMPLIED WARRANTIES

There are no other oral or written warranties, expressed or implied, including but not limited to those of merchantability or fitness for a particular purpose. Any implied warranties are limited in duration to one year from the date of purchase

STATE LAW AND YOUR WARRANTY

This warranty gives you specific legal rights, and you may also have other rights granted under state law. These rights vary from state to state

CONTACT INFORMATION

Taiwan & International
5F No. 135, Jian Yi Rd., Chung Ho City, Taipei, Taiwan
TEL: 886-2-2226-3630
FAX: 886-2-2226-7241
Web Site: www.avermedia.com / www.averdigi.com